

**TECHNICAL DATASHEET**



**Flush-mount multi-channel display  
ATE 300**

- Alternating display of 1 to 3 parameters
- 3 analogue inputs : 3 x 4-20mA or 3 x 0-10V
- 1 RS 232 digital input for KIMO external transmitter (class 200 & 300)
- 1 RS 485 digital input/output (Modbus protocol integrated)
- 22 pre-set units and 3 configurable units
- Configuration via software or remote control
- Electroluminescent front display, made of brushed stainless steel or white lacquered

**Display features**

- Display** .....electroluminescent alphanumeric (38 x 48mm)  
protection screen made of PMMA
- 1<sup>st</sup> line (measurement)** .....4 digits x 8 segments -  $\ell$  14 x  $\ell$  48 mm
- 2<sup>nd</sup> line (unit)** .....4 digits x 14 segments -  $\ell$  14 x  $\ell$  48 mm
- Comma position** .....configurable 0 / 0,0 / 0,00
- Measurement value** .....from -9,99 to 99,99 and from -999 to 9999
- Accuracy** ..... $\pm 0,1$  % of the measurement  $\pm 1$  digit
- Number of channels** .....from 1 to 3 channels, alternatively (3 seconds)
- Location of channels** .....with 3 LED: green, orange, red
- Units available** .....22 pre-set units (see chart)  
3 configurable units
- Response time** .....< 1 sec.

**Housing features**

- Front face** .....316L wire brushed stainless steel  
.....or white lacquered
- Back housing** .....flushmount, 304L stainless steel
- Protection factor** .....IP 65 in front face
- Dimensions** .....see drawing
- Weight** .....600g

**Technical specifications**

- Power supply** .....24 Vac / Vdc  $\pm 10$ %
- Galvanic isolation** .....between input and power supply
- Analogue inputs** .....3 x 4-20 mA (4 wires) or 3 x 0-10 V
- Consumption** .....5 VA
- Electro-magnetical compatibility** .....EN 61 326
- Electrical connection** .....screw terminal block for cables  $\varnothing 1.5$  mm<sup>2</sup> max
- RS 485 communication** .....digital: RTU Modbus protocol  
communication speed configurable  
from 2400 to 115200 Bauds
- RS 232 communication** .....digital: ASCII, proprietary protocol
- Working temperature** .....0 to +50°C
- Storage temperature** .....-10 to +70°C
- Environment** .....air and neutral gases

\* All accuracies indicated in this technical datasheet were stated in laboratory conditions, and can be guaranteed for measurements carried out in the same conditions, or carried out with calibration compensation.

**References**

**Front face**

- B** White lacquered stainless steel  
**I** Brushed stainless steel

ATE-300 -

**Pre-set units**

<b>Air velocity</b>	m/s fpm
<b>Airflow</b>	m <sup>3</sup> /h l/s cfm m <sup>3</sup> /s
<b>Temperature</b>	°C °F
<b>Pressure</b>	Pa mmH <sub>2</sub> O mbar Kpa mmHg inWg PSI
<b>Humidity</b>	%RH g/kg (absolute hygro $\rho$ ) °C (dew point Td) °F (dew point Td) °C (humid temp. Tw) °F (humid temp. Tw) KJ/Kg (Enthalpy i)

## Connection

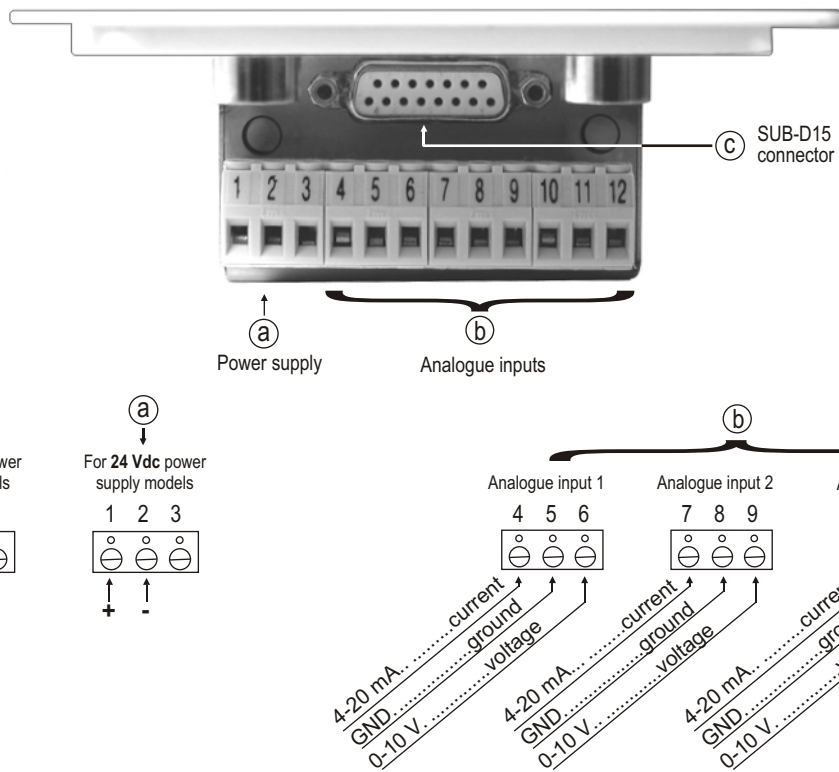

## Electrical connections - as per NFC15-100 norm

⚠ This connection must be made by a qualified technician. Whilst making the connection, the transmitter must not be energized.

### Power supply connection:

- For 24 Vdc power supply models :

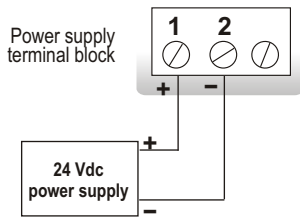

- For 24 Vac power supply models :

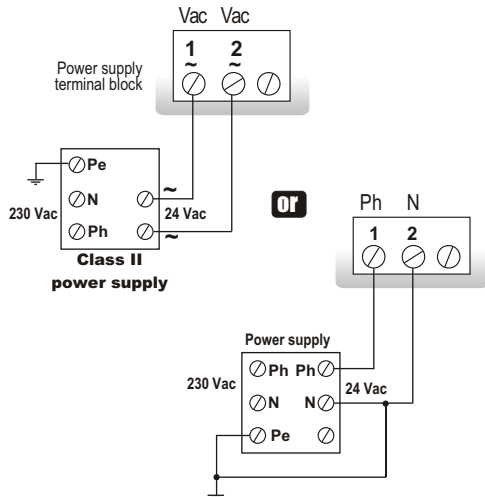

### Input signal selection 0-10V voltage or or 4-20mA current

The switch located on the left side of display enables to select the output type.

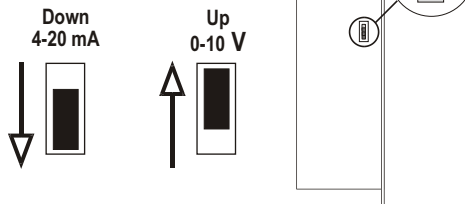

### Input connection:

- 4-20 mA current input :

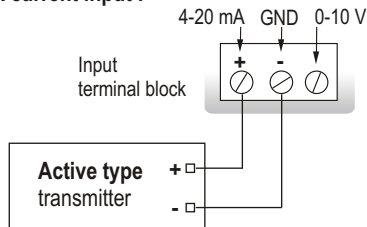

- 0-10 V voltage input :

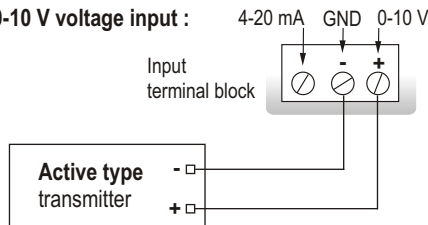

### SUB-D15 connection RS 232 and RS 485 (see © on connection drawing)

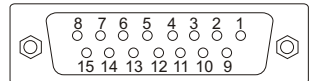

Pin #	Description
1	NC *
2	NC *
3	NC *
4	B - (RS485)
5	A + (RS485)
6	NC *
7	NC *
8	NC *
9	RX (RS 232)
10	NC *
11	TX (RS 232)
12	NC *
13	NC *
14	NC *
15	GND (RS 232)

⚠ CAUTION:  
NC \* --> DO NOT CONNECT

## Analogue / Digital inputs

ATE 300 displays 1 to 3 parameters that can be measured via the following connections:

- **3 analogue inputs:**  
3 x 4-20 mA or 3 x 0-10 V
- **2 analogue inputs and 1 digital input**  
2 x 4-20 mA or 2 x 0-10 V and 1 parameter via RS 232\* connection
- **1 analogue input and 2 digital inputs**  
1 x 4-20 mA or 1 x 0-10 V and 2 parameters via RS 232\* connection

\* parameter(s) from a KIMO external transmitter (Class 200 or 300) connected via Rs232 connection (proprietary protocol)



## Digital communication

### RS 232 communication

- Via the RS 232 connection, ATE 300 can display 1 to 2 parameters which are measured by other KIMO transmitters from Class 200 and 300.
- RS232 communication also enables to configure the transmitter via LCC-300 software.
- RS 232 connection cable is available in 2m, 5m or 10m (maximum) lengths.



### RS 485 Modbus Protocol

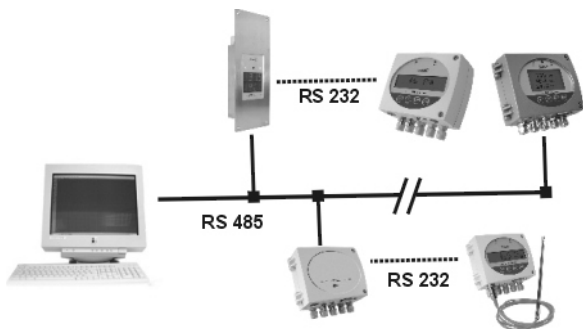

- ATT300 display enables to have a network of transmitters/displays on a RS485 modbus system, or to integrate them in an existing network.
- When one or several transmitters from Class 200 or 300 are connected to ATE 300 display, all information displayed can be sent to BMS via RS485, with only one address.
- RS485 digital communication is a 2-wire network on which transmitters are connected in parallel. They are connected to a PLC/BMS via the RTU Modbus communication system. In the same way as ATT configuration via remote control, Modbus system enables to configure at distance: activate/deactivate a channel, set the measuring ranges of each analogue inputs...
- With RS 485 Modbus protocol, ATT 300 can receive and display measurements carried out by other transmitters via a PLC.

## Configuration

You can configure all parameters: **units, analogue inputs, display channels** ... via the different methods shown below:

- **Via remote control** (optional)  
For transmitters located in hard to reach positions. See configuration manual.
- **Via software** (optional)  
User-friendly configuration. See LCC-300 user manual.
- **Via Modbus** (optional)  
Configuration of all parameters from your PC, via the supervision or data acquisition software.

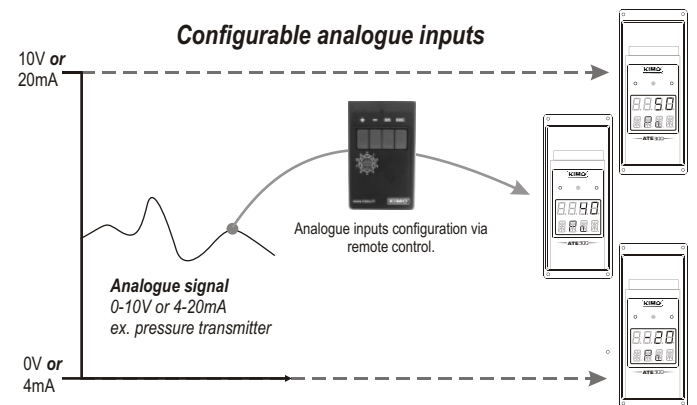

## Housing dimensions

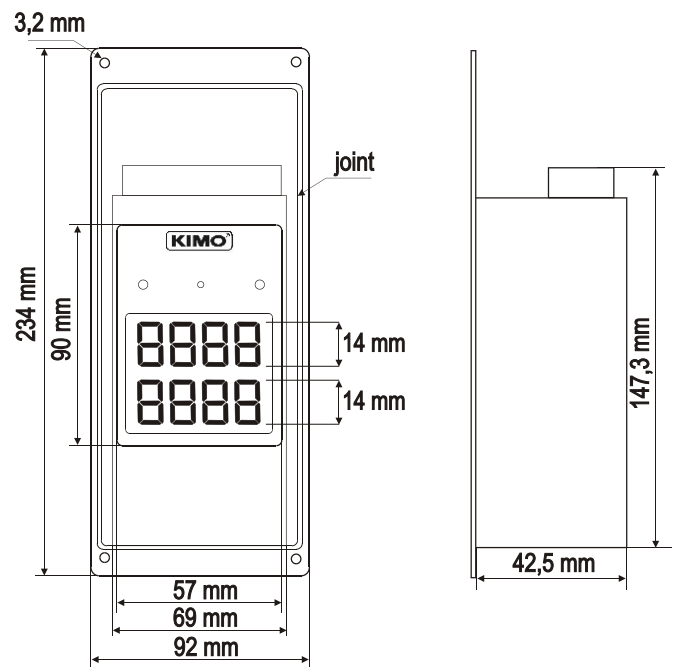

## ■ Mounting

To install the display on a wall, make a cutting of 196 x 70 mm in the wall. Drill 4 holes around the cutting, as shown below. Insert the display into the wall and then, screw the 4 screws (supplied with the transmitter).

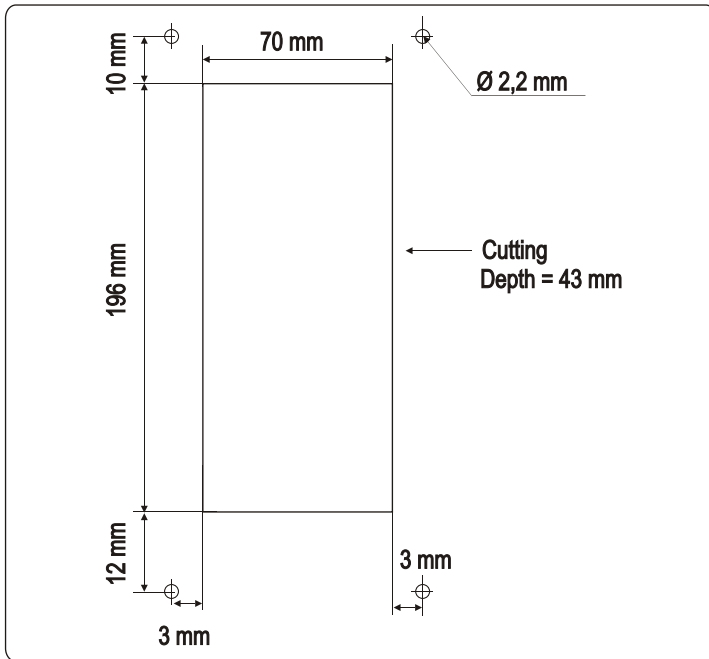

## ■ Maintenance

Avoid aggressive solvents.

## ■ Options

- LCC 300 configuration software with RS 232 cable
- Configuration remote control.

## ■ Optional accessories

- Stainless steel or white lacquered housing for wall-mounting.

### EXPORT DEPARTMENT

Tel : + 33. 1. 60. 06. 69. 25 - Fax : + 33. 1. 60. 06. 69. 29  
site : [www.kimo.fr](http://www.kimo.fr) e-mail : [export@kimo.fr](mailto:export@kimo.fr)



Distributed by :

