

TECHNICAL DATASHEET

New

CE



**Humidity transmitter
HM 50**

- Humidity transmitter type HM 50
- Range 0-100 %RH
- 0-10 V output, active sensor, power supply 24 Vac/Vdc (3-4 wires) or 4-20 mA output, passive loop, power supply 18 to 30 Vdc (2 wires)
- ABS IP 30 housing, without display
- Quick and easy mounting with the "¼ turn" system with wall-mount plate

Part number

To order, just add the code to complete the part number :

Transmitter/ Power supply / Output

V	Active • 24 Vac/Vdc • 0-10V
A	Passive • 18/30 Vdc • 4-20 mA



Example : HM 50-A
Model : humidity transmitter HM 50, passive loop 4-20 mA.

Dimensions

(with wall-mount plate)

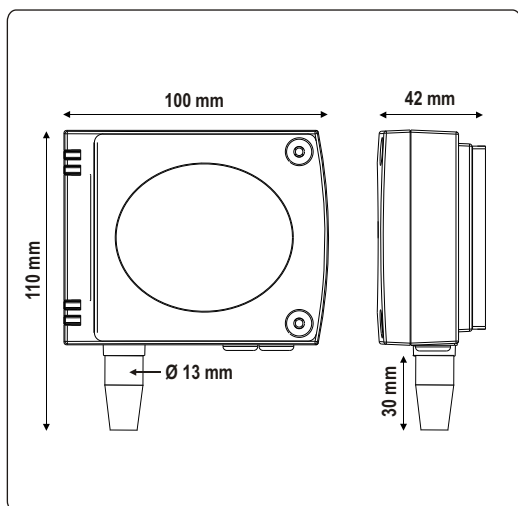

Features of the transmitter

Humidity

Working principle : the measurement of humidity is made by only one digital component CMOS (complementary metal-oxide semiconductor), including a capacitive element and a thermistor. This technology guarantees an excellent stability in the long term, along with a great accuracy of the measurement.

Measuring range.....	0 to 100 %RH
Unit of measurement.....	% RH
Response time.....	1/e (63%) 4 s
Type of fluid.....	air and neutral gases

HYGROMETRY PROBE :

Guaranteed Accuracy Limits* (GAL) = ±2,95 % RH between 18 and 28°C (normal measurement range)
Measuring range : 0 to 100%RH
Short-term drift : 1%RH / year

* GAL = Et + Ehl + k (uet²+ur²+ud²+us²)/2

As per the Charter 2000/2001 Hygrometers with :
uet : uncertainty of calibration = ± 0,55%RH
ur : uncertainty of resolution = ± 0,003%RH
ud : manufacturing dispersion = ± 0,2%RH
us : comparison repeatability = 0,13%RH
Et : temperature coefficient error = ± 0,42%RH
Ehl : Linearity and hysteresis errors = ± 1,33%RH
k : coverage factor value = 2

* As per norm NFX 15-113 and the Charter "2000-2001 HYGROMETERS".

Features of the housing

Housing.....	ABS
Fire-proof classification.....	HB as per UL94
Dimensions.....	see drawing beside
Protection.....	IP 30
Cable grip.....	for cables Ø 7 mm max.
Weight.....	110 g

Technical Specifications

Output/ Power supply.....	active sensor 0-10 V (power supply 24 Vac/Vdc ±10%), 3-4 wires passive loop 4-20 mA (power supply 18/30 Vdc), 2 wires maximum load : 500 Ohms (4-20 mA) minimum load : 1 K Ohms (0-10 V)
Consumption.....	2 VA(0-10V) or max. 22 mA (4-20 mA)
Electro-magnetical compatibility.....	EN 61326
Electrical connection.....	screw terminal block for cable Ø 1.5 mm ² max.
Communication to PC.....	Kimo RS 232 cable
Working temperature.....	+10 to +40°C
Storage temperature.....	-10 to +70°C
Environment.....	air and neutral gases

Connection



For the model
HM 50-V • 0-10 V output - active sensor

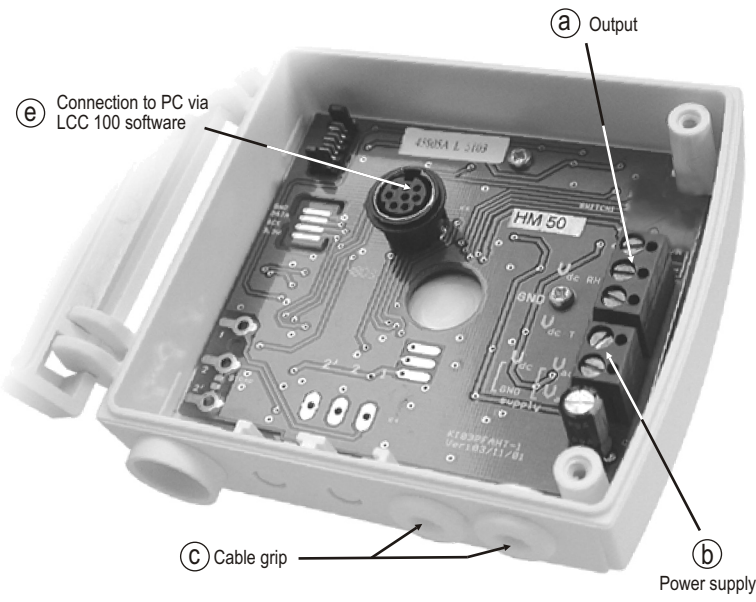

(e) Connection to PC via LCC 100 software

(c) Cable grip

(b) Power supply

(c) Cable grip : to insert the cable, it is required to slightly cut the rubber.

Output

- (a) $\begin{matrix} \text{Vdc RH} & \dots\dots & \text{direct voltage (humidity)} \\ \text{GND} & \dots\dots & \text{ground} \end{matrix}$

Power supply

- (b) $\begin{matrix} \text{Vdc} & \dots\dots & \text{direct voltage} \\ \text{GND} & \dots\dots & \text{ground} \end{matrix}$

OR

- (b) $\begin{matrix} \text{Vac} & \dots\dots & \text{alternative voltage (phase)} \\ \text{Vac} & \dots\dots & \text{alternative voltage (neutral)} \end{matrix}$

For the model

HM 50-A • 4-20 mA output - passive loop

(a) Output terminal block

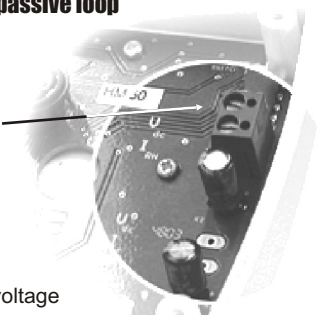

- (a) $\begin{matrix} \text{Vdc} & \dots\dots & \text{direct voltage} \\ \text{IRH} & \dots\dots & \text{direct current (humidity)} \end{matrix}$

Electrical connection - as per norm NFC15-100

! This connection must be made by a qualified technician. To make the connection, the transmitter must not be energized.

For the model
HM 50-V • 0-10 V output - active sensor

4 wires

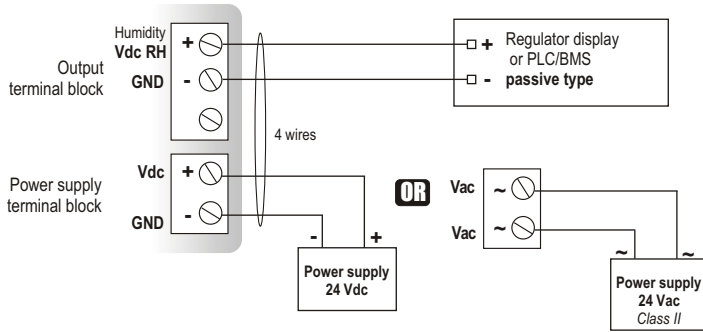

3 wires

! To make a 3-wire connection, before powering up the transmitter, please connect the output ground to the input ground. See drawing below.

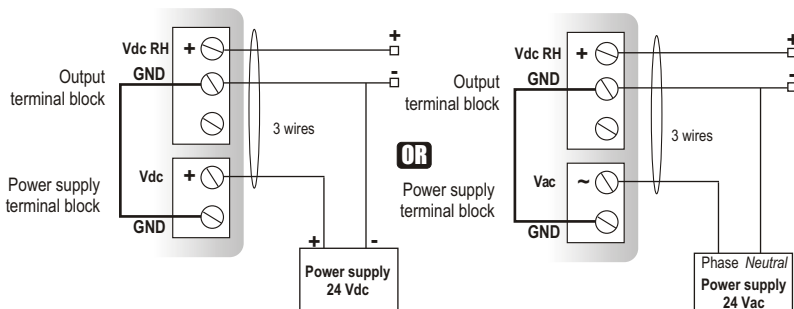

For the model
HM 50-A • 4-20 mA output - passive loop

2 wires

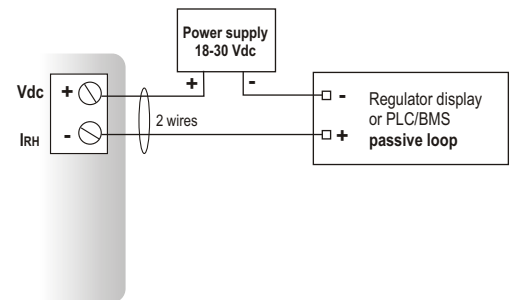

OR

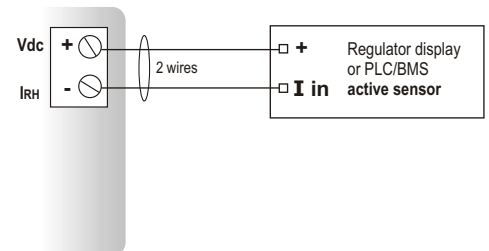

■ Configuration

You can configure the offset of the transmitter via **software** (connection ④ on “connection” drawing).

In order to balance an eventual drift of the transmitter, you can add an offset to the value measured by the HM 50

Example :

=> the HM50 indicates 48%RH, the standard reference indicates 45%RH

=> via the software LCC 100, you can add an offset of “-3” to the value.

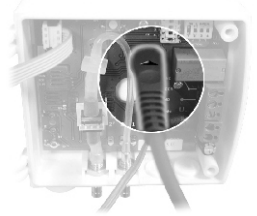

- Please refer to the user manual of the LCC 100 to configure the offset.

■ Mounting

Installation : mount the ABS plate on the wall (this plate is supplied with the transmitter). Drilling : \varnothing 6 mm (with the screws and pins supplied with the transmitter). Insert the transmitter into the plate (see points A of the drawing shown beside), by tilting it at 30°. Rotate the housing in clockwise direction until you hear a “click” which confirms that the transmitter is correctly installed.

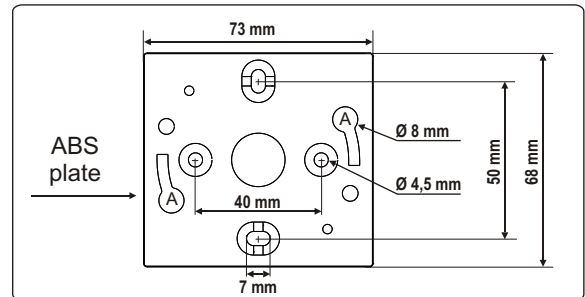

■ Maintenance

Please avoid any aggressive solvent.

Please protect the transmitter and its probes from any cleaning product containing formol, that may be used for cleaning rooms or ducts.

■ Options

- Power supply class 2, input 230 Vac, output 24 Vac, ref.KIAL-100A
- Configuration software LCC 100 with RS 232 cable.



EXPORT DEPARTMENT

Tel : + 33. 1. 60. 06. 69. 25 - Fax : + 33. 1. 60. 06. 69. 29
site : www.kimo.fr e-mail : export@kimo.fr



Distributed by :