

TECHNICAL DATASHEET

New
CE



Temperature transmitter TG 100

- Duct temperature transmitter, TG100 type
- Measuring ranges from 0 to +50°C, -20 to +80°C, -50 to +50°C, 0 to +100°C, 0 to 200°C, 0 to +300°C, 0 to +400°C (according to model, see "Configuration")
- 0-10 V output, active sensor, power supply 24 Vac/Vdc (3-4 wires) or 4-20 mA output, passive loop, power supply 18 to 30 Vdc (2 wires)
- ABS IP 65 housing, with or without display
- Quick and easy mounting "1/4 turn" system with wall-mount plate

Part number

To order, just add the codes to complete the part number :

Transmitter / power supply / output

V Active • 24 Vac/Vdc • 0-10V
A Passive • 18/30 Vdc • 4-20 mA

Display

O With display
N Without display

Mounting

A Duct mount
B Terminal block

TG100 -

Example : TG100-VOA

Model : temperature transmitter TG 100 active sensor 0-10 V output, with display and duct mount probe.

Dimensions of the housing

(with wall-mount plate)

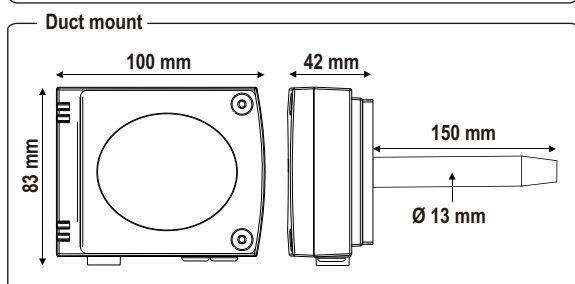
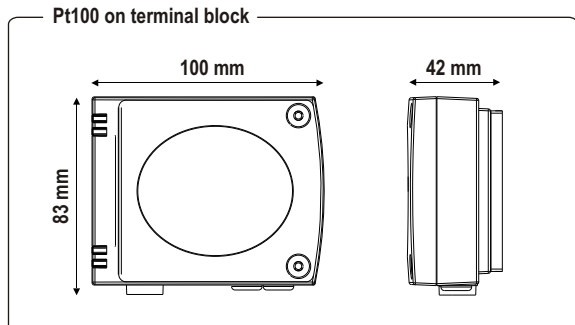

Features of the transmitter

Temperature

Working principle : Pt100 is a resistance with a positive temperature coefficient which varies according to the temperature. The higher the temperature is, the more the value of the resistance increases.
Example : for 0°C \simeq 100 Ω - for 100°C \simeq 138,5 Ω

Measuring rangesee chart "Configuration"

Units of measurement°C, °F

Accuracy * \pm 0,5% of reading \pm 0,4°C (duct mount probe)
according to the probe (Pt 100 on terminal block)

Response time1/e (63%) 5 sec. (duct mount probe)
according to the probe (Pt 100 on terminal block)

Resolution0,1°C

Type of sensor.....Pt 100 class A as per DIN IEC751

Type of fluid.....air et neutral gases

WITH or WITHOUT display

Features of the housing

HousingABS

Fire-proof classification.....HB as per UL94

Dimensionssee drawings beside

ProtectionIP 65

Display5- digit LCD. Dimensions 50 x 15 mm

Height of the digits10 mm

Cable gripfor cables \varnothing 7mm maxi.

Weight.....145g (with display) - 110g (without display)



Technical Specifications

Output / power supplyactive transmitter 0-10 V (power supply 24 Vac/Vdc \pm 10%), 3-4 wires
passive loop 4-20 mA (power supply. 18/30 Vdc), 2 wires
maximum load : 500 Ohms (4-20 mA)
minimum load : 1 K Ohms (0-10 V)

Consumption2 VA (0-10V) or max. 22 mA (4-20mA)

Electro-magnetical compatibilityEN 61326

Electrical connectionscrew terminal block for cables \varnothing 1.5 mm² max

Communication to PC Kimo RS 232 cable

Working temperature (housing)0 to +50°C

Working temperature (probe)-20 to +80°C (duct mount probe)
according to the probe (Pt100 on terminal block)

Storage temperature-10 to +70°C

Environmentair and neutral gases

*All the accuracies indicated in this technical datasheet were stated in laboratories conditions, and can be guaranteed for measurements carried out in the same conditions, or carried out with calibration compensation.

Connection



For the models
TG 100 - VOA, TG 100 - VNA • Output 0-10 V active sensor

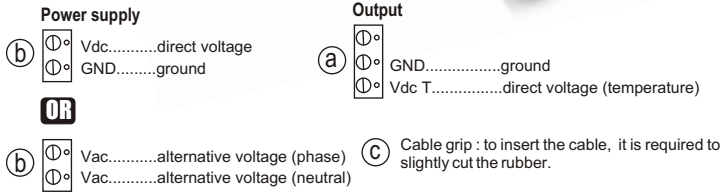
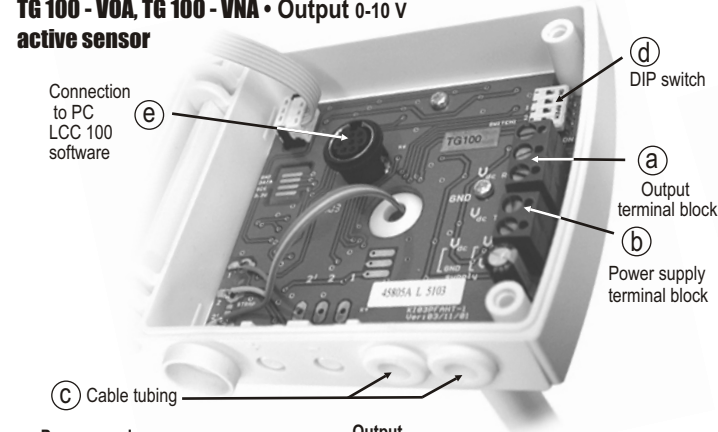

For the models
TG 100 - VOB, TG 100 - VNB • Output 0-10 V - active sensor

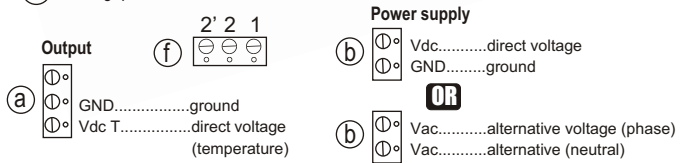
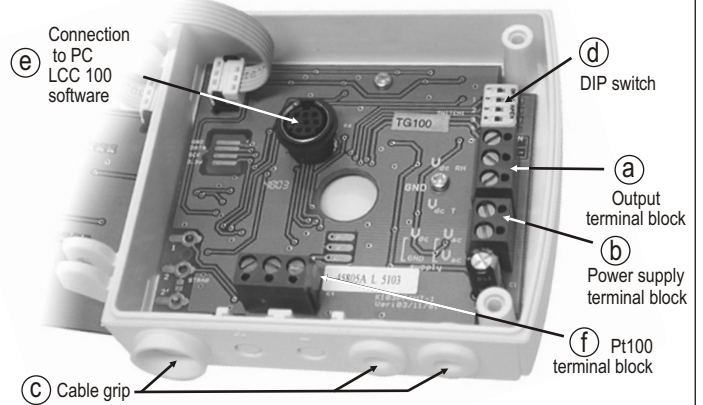

For the models
**TG 100 - AOA, TG 100 - ANA
 Output 4-20 mA - passive loop**

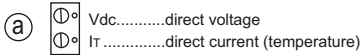
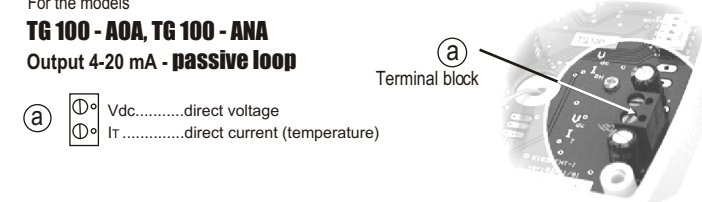

For the models
**TG 100 - AOB, TG 100 - ANB
 Output 4-20 mA - passive loop**

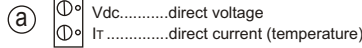
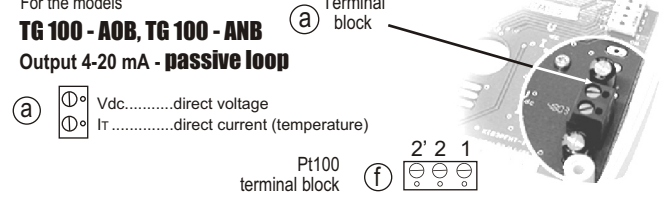

Electrical connection - as per norm NFC15-100

⚠ This connection must be made by a qualified technician. To make the connection, the transmitter must not be energized.

For the models
TG 100 - VOA, TG 100 - VNA, TG 100 - VOE, TG 100 - VNE • Output 0-10 V - active loop

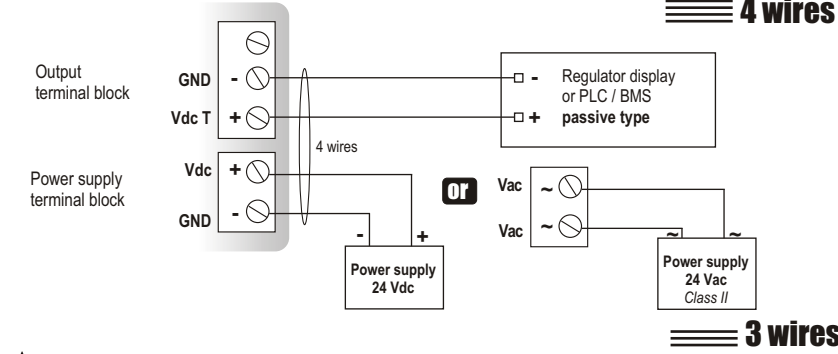

⚠ To make a 3-wire connection, before powering up the transmitter, please connect the ground to the output of the input ground. See drawing below.

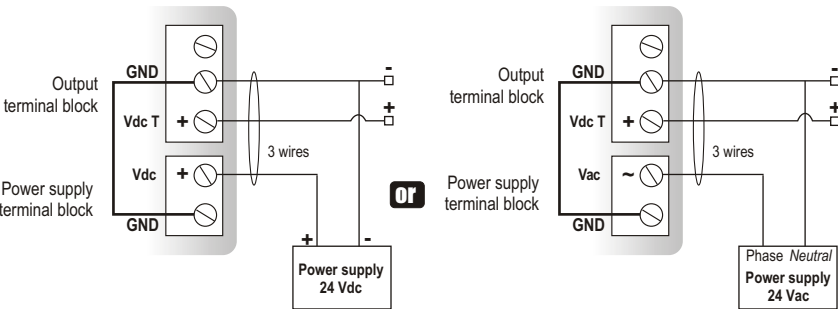

For the models
**TG 100 - AOA, TG 100 - ANA, TG 100 - AOE, TG 100 - ANE
 • Output 4-20 mA - passive loop**

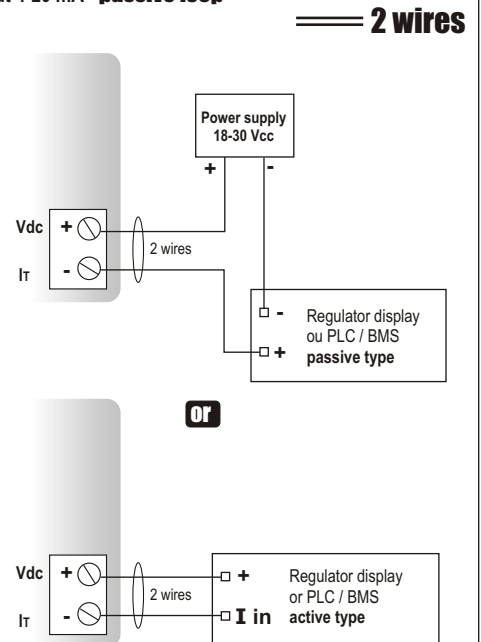

**Connection of the Pt100 probe
 for the models
 TG 100 - VOB, TG 100 - VNB, TG 100 - AOB, TG 100 - ANB**

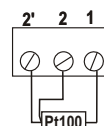

Configuration

It is possible to configure the measuring ranges, the units, the output of the transmitter (according to the model) either by **DIP switch** and/or via **software** (connections ③ and ④ on drawing "connection")

Configuration by DIP switch

To configure the transmitter, please unscrew the 2 screws from the housing, and then open it.



Identification of DIP switch on the board

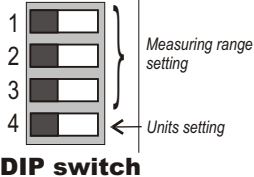

DIP switch

On-off switch

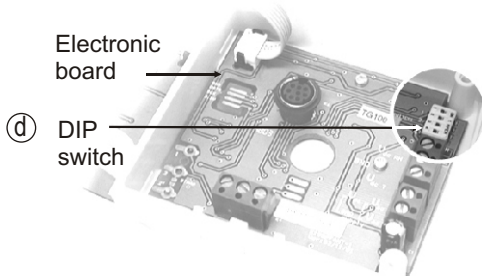

To configure the transmitter, **it must not be energized**. Then, you can make the settings required, with the DIP switches (as shown on the drawing beside). When the transmitter is configured, you can power it up.

Caution!

Please follow carefully the combinations beside with the DIP switch.

If the combinations are wrong, the following message will appear on the display of the transmitter "CONF ERROR". In that case, you will have to unplug the transmitter, place the DIP switches correctly, and then power the transmitter up.

Units setting

To set the measuring unit, please put the on-off switch 4 of units, as shown beside.

Configurations	°C	°F
Combinations	1	1
	2	2
	3	3
	4	4

Measuring range setting

To set the measuring range, please put the on-off switches 1, 2 and 3 of the measuring range, as shown beside.

Configurations	Measuring range Pt 100 on terminal block						
	Measuring range duct mount						
	0 to 50 °C	-20 to 80 °C	-50 to 50 °C	0 to 100 °C	0 to 200 °C	0 to 300 °C	0 to 400 °C
Combinations	1	1	1	1	1	1	1
	2	2	2	2	2	2	2
	3	3	3	3	3	3	3
	4	4	4	4	4	4	4

Initialization the transmitter

When the transmitter is powered up, it initializes and displays the digits $\overline{0000}$, and then its configuration including :

- the measuring range
- the analog output.

1- The measuring range

The following message is displayed : \overline{Lo} . This is the low value of the measuring range, and its digit value : **ex** : $\overline{0}$.
 The following message is displayed : \overline{Hi} . This is the high value of the measuring range and its digit value : **ex** : $\overline{400}$.
 The arrow displayed (at the bottom or on the right of the screen) is relative to the unit of measurement : **ex** : from 0 to 400 °C.

2- The analog output

If the analog output is in 4-20mA, then the following message will appear $\overline{4-20A}$.
 If the analog output is 0-10 V, then the following message will appear $\overline{0-10V}$.

After the display of the configuration, the transmitter displays $\overline{- - - -}$, which confirms that the initialization is finished and you can start the measurements.

■ Configuration via **software**

(with optional LCC100 software)



An easy and friendly configuration with the software !

You can configure your own intermediary ranges.

Example : for a transmitter with a range of -50 to +400°C, the minimum configurable range is 50°C. For example, you can configure your transmitter with a range from -50 to +350°C, or from +300 to +350°C...

• To access the configuration via software, you must first position the **DIP switches** as per the following picture (shown beside), and then connect the cable to the transmitter (see beside and see "Connection").

• **Please refer to the user manual of the LCC 100 to make the configuration.**

⚠ Caution !

The configuration of the parameters can be done **either with the DIP switch, or via software** (you cannot combine both solutions).

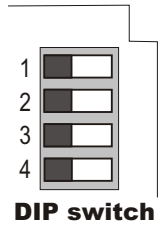

DIP switch



■ **Mounting**

Installation : mount the ABS plate on the wall (this plate is supplied with the transmitter). Drilling : \varnothing 6 mm (with the screws and pins supplied with the transmitter). Insert the transmitter on the plate (see A on the drawing beside) and rotate its housing in clockwise direction until you hear a "click" which confirms that the transmitter is correctly installed.

For the model with duct mount, an additional drilling of \varnothing 14mm must be done before mounting the ABS plate.

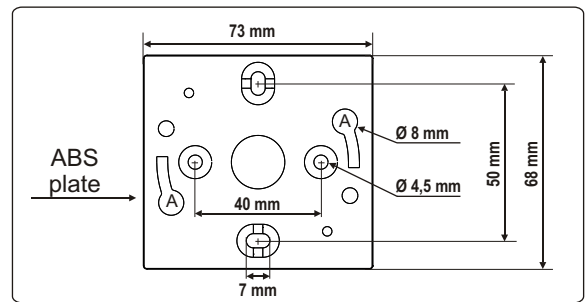

■ **Maintenance**

Please avoid any aggressive solvent.

Please protect the transmitter and its probes from any cleaning product containing formol, that may be used for cleaning rooms or ducts.

■ **Options**

- Power supply class 2, input 230 Vac, output 24 Vac, ref.KIAL-100A
- Configuration LCC 100 software with RS 232 cable
- Temperature probes Pt100 3 wires (for model TG 100 on terminal block)



■ **Accessories**

- Connection tube
- Connection fittings
- Through-connections
- Straight connections
- Spherical coupling nut



EXPORT DEPARTMENT

Tel : + 33. 1. 60. 06. 69. 25 - Fax : + 33. 1. 60. 06. 69. 29
 site : www.kimo.fr e-mail : export@kimo.fr



Distributed by :