

TECHNICAL DATASHEET

New

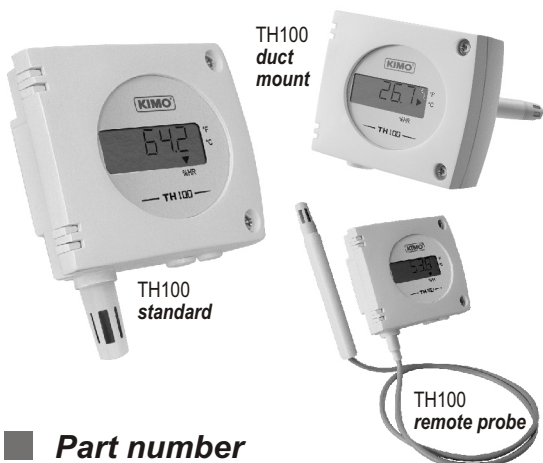

Temperature and humidity transmitter TH 100

- Humidity and temperature transmitter type TH100.
- Measuring ranges 0-100%RH and -50 to +50°C, -20 to +80°C, 0 to +50°C, 0 to +100°C (see "Configuration")
- 0-10 V output, active sensor, power supply 24 Vac/Vdc (3-4wires) or 4-20 mA output, passive loop, power supply 18 to 30 Vdc (2 wires).
- Housing ABS IP 65 with or without display
- Alternating display of humidity and temperature
- Quick and easy mounting "1/4 turn" system on wall-mount plate.

Part number

To order, just add the codes to complete the part number :

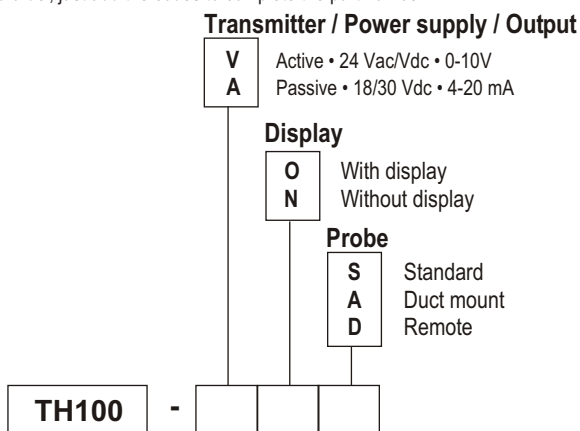

Example : TH100-VOD

Model : temperature and humidity transmitter TH 100, active sensor, 0-10 V output, with display and remote probe.

Dimensions of the housing

(including the wall-mount plate)

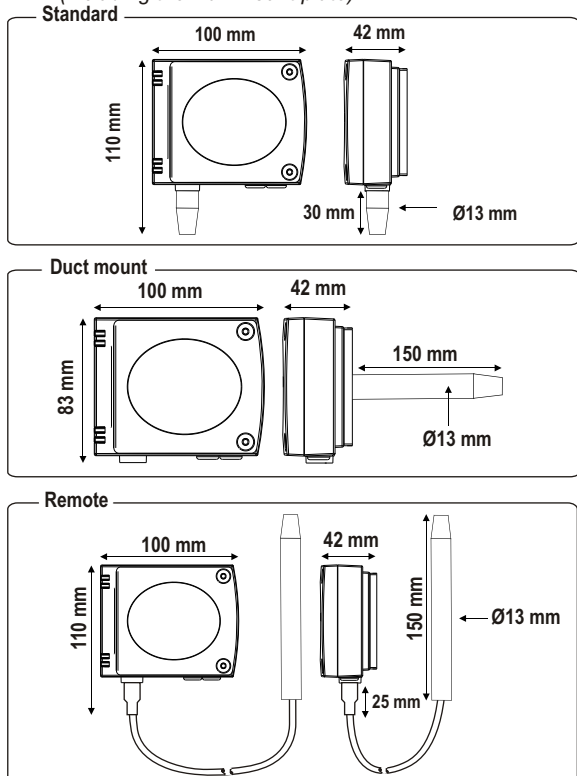

Features of the transmitter

Humidity

Working principle : the measurement of temperature and humidity is made by only one digital component CMOS (complementary metal-oxide semiconductor), including a capacitive element and a thermistor. This technology guarantees an excellent stability in the long term, along with a great accuracy of the measurement.

- Measuring range.....0 to 100 % RH
- Unit of measurement.....% RH
- Response time.....1/e (63%) 4 s
- Resolution.....0,1% RH
- Type of fluid.....air and neutral gases

HYGROMETRY PROBE :

Guaranteed Accuracy Limits* (GAL) = ±2,95 % RH between 18 and 28°C (normal measurement range)
Measuring range : 0 to 100%RH
Short-term drift : 1% RH / year

* GAL= Et + Ehl + k (uet²+ur²+ud²+us²)/2

As per the Charter 2000/2001 Hygrometers with :
uet : uncertainty of calibration = ± 0,55% RH
ur : uncertainty of resolution = ± 0,003% RH
ud : manufacturing dispersion = ± 0,2% RH
us : comparison repeatability = 0,13% RH
Et : temperature coefficient error = ± 0,42%RH
Ehl : linearity and hysteresis errors = ± 1,33% RH
k : coverage factor value = 2

* As per norm NFX 15-113 and the Charter "2000-2001 HYGROMETERS.

Temperature

- Measuring range0 to +50°C, -20 to +80°C, -50 to +50°C, 0 to +100°C
- Unit of measurement.....°C, °F
- Accuracy *±1% of reading ±0,4°C in the range 5 to 80°C
±2% of reading ±0,6°C in the range -20 to 5°C
- Response time1/e (63%) 15 s
- Resolution.....0,1°C
- Type of fluid.....air and neutral gases

*All the accuracies indicated in this technical datasheet were stated in laboratories conditions, and can be guaranteed for measurements carried out in the same conditions, or carried out with calibration compensation.

Features of the housing

- HousingABS
- Fire-proof classificationHB as per UL94
- Dimensionssee drawing beside
- Protection.....IP65
- Display5-digit LCD. Dimensions 50 x 15 mm
Alternating display of humidity and temperature.
- Height of the digits10 mm
- Cable gripfor cable Ø 7 mm maxi.
- Weight.....145 g (with display) - 110g (without display)

WITH or WITHOUT display



Technical Specifications

Output / Power supplyactive 0-10 V (power supply 24 Vac/Vdc $\pm 10\%$), 3-4 wires
 passive loop 4-20 mA (power supply 18/30 Vdc), 2 wires
 maximum load : 500 Ohms (4-20 mA)
 minimum load : 1 K Ohms (0-10 V)

Consumption2 VA (0-10V) or max. 22 mA (4-20 mA)

Electro-magnetical compatibility ...EN 61326

Electrical connectionscrew terminal block for cable \varnothing 1.5 mm² max.

Communication to PC Kimo RS 232 cable

Working temperature(housing)0 to +50°C

Working temperature (probe)0 to +50°C (standard)
 -20 to +80°C (remote and duct mount)

Storage temperature-10 to +70°C

Environmentair and neutral gases

Connection



For the models

TH 100 - AOS, TH100 - ANS, TH 100 - AOD, TH 100 - AND, TH 100 - AOA, TH 100 - ANA • Output 4-20 mA - **passive loop**

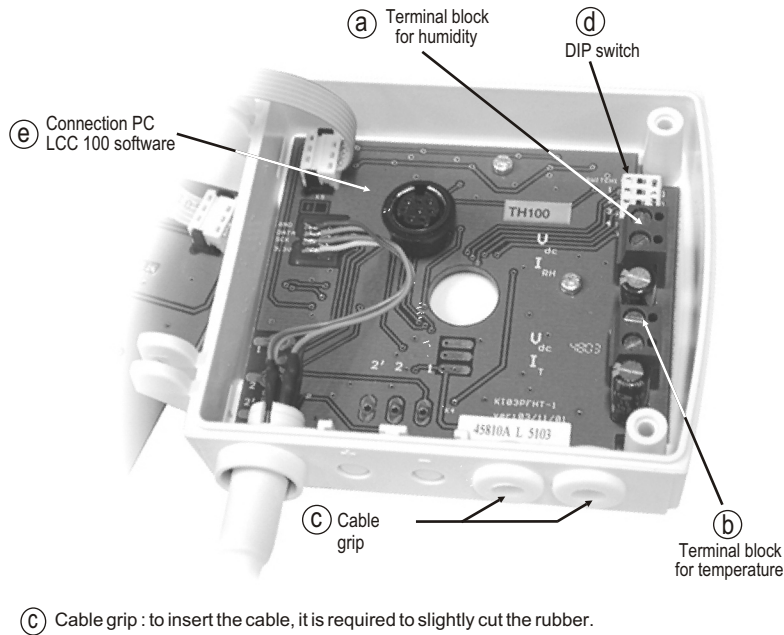

- (a) $\begin{matrix} \text{Vdc} & \dots\dots & \text{direct voltage} \\ \text{IRH} & \dots\dots & \text{direct current (humidity)} \end{matrix}$
- (b) $\begin{matrix} \text{Vdc} & \dots\dots & \text{direct voltage} \\ \text{IT} & \dots\dots & \text{direct current (temperature)} \end{matrix}$

For the models

TH 100 - VOS, TH100 - VNS, TH 100 - VOD, TH 100 - VND, TH 100 - VOA, TH 100 - VNA • Output 0-10 V - **active**

- (a) $\begin{matrix} \text{Vdc RH} & \dots\dots & \text{direct voltage (humidity)} \\ \text{GND} & \dots\dots & \text{ground} \\ \text{Vdc T} & \dots\dots & \text{direct voltage (temperature)} \end{matrix}$

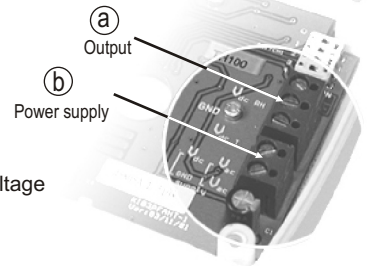

Power supply

- (b) $\begin{matrix} \text{Vdc} & \dots\dots & \text{direct voltage} \\ \text{GND} & \dots\dots & \text{ground} \end{matrix}$
- OR**
- (b) $\begin{matrix} \text{Vac} & \dots\dots & \text{alternative voltage (phase)} \\ \text{Vac} & \dots\dots & \text{alternative voltage (neutral)} \end{matrix}$

Electrical connection - as per norm NFC15-100

! This connection must be made by a qualified technician. To make the connection, the transmitter must not be energized.

For the models

TH 100 - AOS, TH100 - ANS, TH 100 - AOD, TH 100 - AND, TH 100 - AOA, TH 100 - ANA • Output 4-20 mA - **passive**

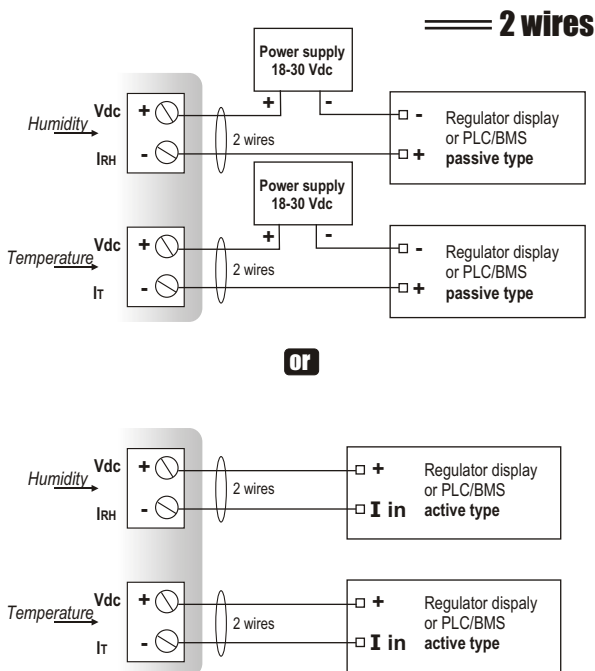

For the models

TH 100 - VOS, TH100 - VNS, TH 100 - VOD, TH 100 - VND, TH 100 - VOA, TH 100 - VNA • Output 0-10 V - **active**

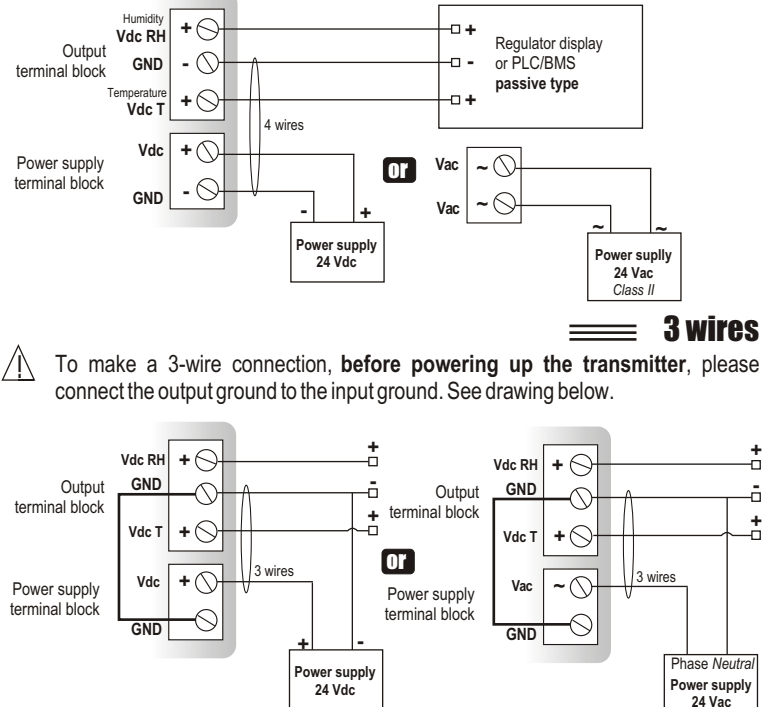

Configuration

It is possible to configure the measuring ranges, the units, the output of the transmitter (according to the model) either by **DIP switch** and/or via **software** (connections ③ and ④ on drawing "connection").

Configuration by DIP switch

To configure the instrument, please unscrew the 2 screws from the housing, and then open it .

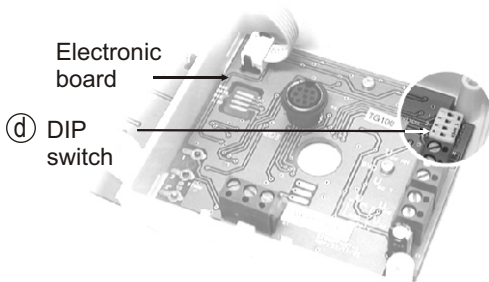

Identification of the DIP switches on the electronic card

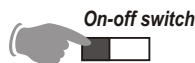
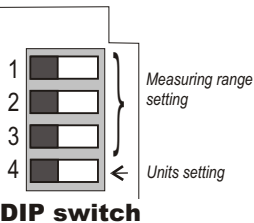

To configure the transmitter, **it must not be energized**. Then, you can make the settings required, with the DIP switches (as shown on the drawing beside). When the transmitter is configured, you can power it up.



Caution !

Please follow carefully the combinations beside with the DIP switch.

If the combination are wrongly done, the following message will appear on the display of the transmitter "CONFERROR". In that case, you will have to unplug the transmitter, replace the DIP switches correctly, and then power the transmitter up.

Units setting

To set the measuring unit, put the on-off switch 4 of units as shown beside.

Configurations	°C	°F
Combinations	1	1
	2	2
	3	3
	4	4

Measuring range setting

To set the measuring range, put the on-off switches 1, 2 and 3 of the measuring range as shown beside.

Configurations	0 to 50 °C	-20 to 80 °C	-50 to 50 °C	0 to 100 °C
Combinations	1	1	1	1
	2	2	2	2
	3	3	3	3
	4	4	4	4

Initialization the transmitter

When the transmitter is powered up, it initializes and displays the digits 00.0000, and then its configuration including :
 - the measuring range
 - the analog output.

1- The measuring range

The following message is displayed : Lo . This is the low value of the measuring range, and its digit value : **ex** : 0 .

The following message is displayed : Hi . This is the high value of the measuring range and its digit value : **ex** : 100 .

The arrow displayed (at the bottom or on the right of the screen) is relative to the unit of measurement : **ex** : from 0 to 100 %RH.

2- The analog output

If the analog output is in 4-20mA, then the following message will appear 4-20A .

If the analog output is 0-10 V, then the following message will appear 0-10V .

The transmitter can measure several parameters (TH 100 => humidity + temperature). The transmitter will first display the configuration of humidity parameters, and secondly the configuration of temperature parameters.

After the display of the configurations, the transmitter displays ----, which confirms that the initialization is finished and you can start the measurements.

■ **Configuration by software** (LCC100 coming in option)



An easy and friendly configuration with the software !

You can configure your own intermediary ranges, the offset...

Example :

- For a transmitter from 0-100°C, the minimum delta of the range is 50°C. You can also configure your transmitter from 0 to +70°C, or from -10 to +40°C...
- In order to avoid any eventual drift of the transmitter, you can add an offset to the value displayed by the TH 100. For example : the TH100 displays 48%RH, a standard instrument displays 45%RH. Then, you can integrate an offset of -3 to the value displayed by the TH 100, thanks to the LCC100 software.

To have access to the configuration with software, **first of all**, it is required to **set the DIP switch as shown below**, then to connect the cable to the transmitter (see beside and see "Connection"). **To make the configuration, please refer to the user manual of the LCC 100.**

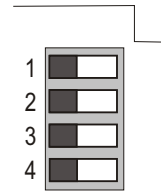

DIP switch



Caution !

The configuration of the parameters can be done **either by DIP switch, OR by software** (you cannot combine both solutions).

■ **Mounting**

To make the wall-mounting, install the ABS plate onto the wall (this plate is supplied with the transmitter). Drilling : Ø 6 mm (with the screws and pins supplied with the transmitter).

Insert the transmitter on the plate (see A on the drawing beside) and make its housing rotated in clockwise direction till you hear a "click", which confirms that the transmitter is correctly installed).

For the model with duct want an additional drilling of Ø 14 mm must be done.

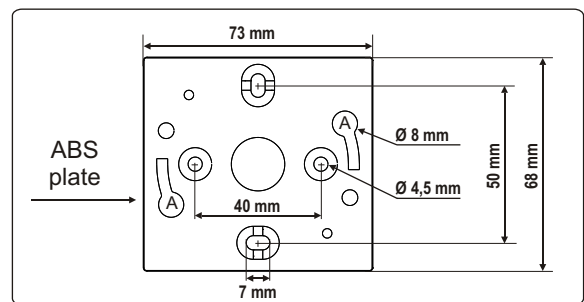

■ **Maintenance**

Please avoid any aggressive solvent.
Please protect the transmitter and its probes from any cleaning product containing formol, that may be used for cleaning rooms or ducts.

■ **Options**

- Power supply class 2, input 230 Vac, output 24 Vac, ref.KIAL-100A
- Configuration software LCC 100 with cable RS 232



■ **Accessories**

- Stainless steel connection
- PC connection gland
- ABS connection with connection gland
- Stainless steel connections
- Wall-mount plate for humidity remote probe

EXPORT DEPARTMENT

Tel : + 33. 1. 60. 06. 69. 25 - Fax : + 33. 1. 60. 06. 69. 29
site : www.kimo.fr e-mail : export@kimo.fr



Distributed by :