

TECHNICAL DATASHEET

New

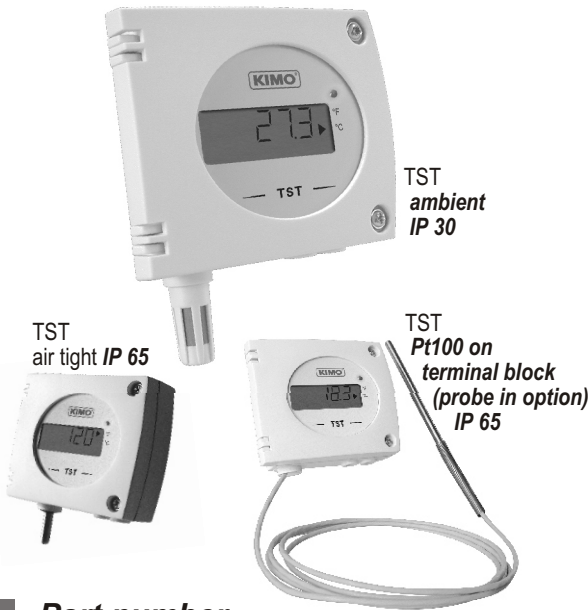

**Thermostats
TST**



- Measuring ranges from 0 to +50°C, -20 to +80°C, -50 to +400°C
- RCR relay output 3A/230Vac. Power supply 24Vac/Vdc
- Visual alarm, red LED in front
- ABS IP 65 and IP 30 housing, with display
- Quick and easy mounting with the "¼ turn" system with wall-mount plate

Features of the transmitter

Temperature

A Pt100 is a resistance with a positive temperature coefficient which varies according to the temperature. The higher the temperature is, the more the value of the resistance increases.

Example : for 0°C ≈ 100 Ω - for 100°C ≈ 138,5 Ω

Measuring ranges 0 to +50°C (ambient model)
 -20 to +80°C (air tight model)
 according to the probe : -50 to +400°C
 (Pt100 input on terminal block)

Unit of measurement °C, °F

Accuracy * ±1% of reading ±0,4°C

Operating time 1/e (63%) 5 sec. (ambient model)
 1/e (63%) 20 sec. (air tight model)
 according to probe (Pt100 input on terminal block)

Resolution 0,1°C

Type of transmitter Pt 100 class A as per DIN IEC 751

Type of fluid air and neutral gases

Features of the housing

Housing ABS

Fire-proof classification HB as per UL94

Dimensions see drawing beside

Protection IP30 (ambient model)
 IP65 (air tight and Pt100 on terminal block models)

Display 5-digit LCD. Dimensions 50 x 15 mm

Height of the digits 10 mm

Cable grip for cables Ø 7 mm max.

Weight 145 g

Technical specifications

Output 1 RCR relay 3A/230 Vac

Relay and alarm status red LED in front

Set point 1 configurable set point

Power supply 24 Vac/Vdc ±10%

Consumption 2 VA

Electromagnetic compatibility EN 61326

Electrical connection screw terminal block for cable Ø 1.5 mm² max.

Communication to PC Kimo RS 232 cable

Working temperature +10 to +40°C (ambient model)

-10 to +50°C (air tight model)
 according to probe (Pt100 input on terminal block)

Storage temperature -10 to +70°C

Environment air and neutral gases

Part number

To order, just add the code to complete the part number :

Probe	
M	Ambient
E	Air tight
B	Pt100 input, on terminal block



Example : TST-B corresponds to a TST thermostat with Pt 100 input on terminal block (probe in option).

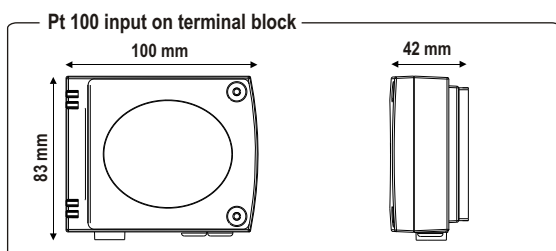
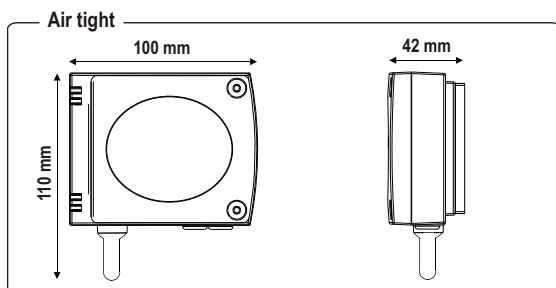
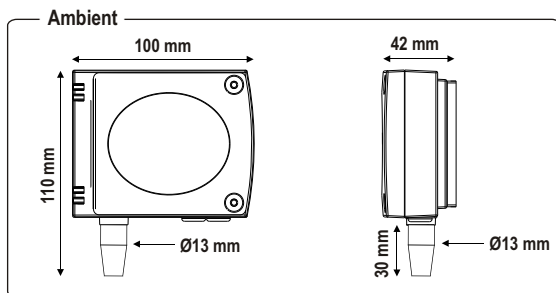

*All the accuracies indicated in this technical datasheet were stated in laboratory conditions, and can be guaranteed for measurements carried out in the same conditions, or carried out with calibration compensation.

Connection



For models
TST-M and **TST-E**

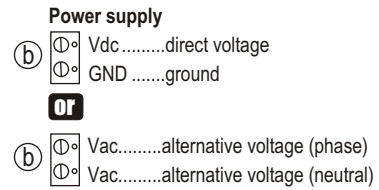
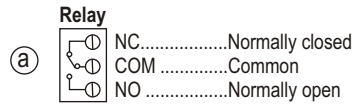
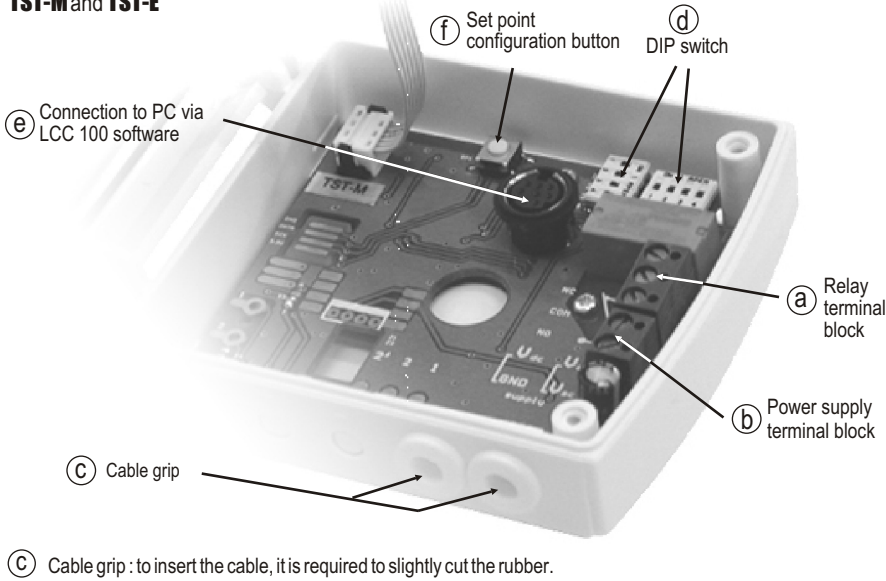

For model

TST-B

(d) Pt100
terminal
block



Electrical connections - as per norm NFC15-100

This connection must be made by a qualified technician. To make the connection, the transmitter must not be energized.

For models
TST-M and **TST-E**

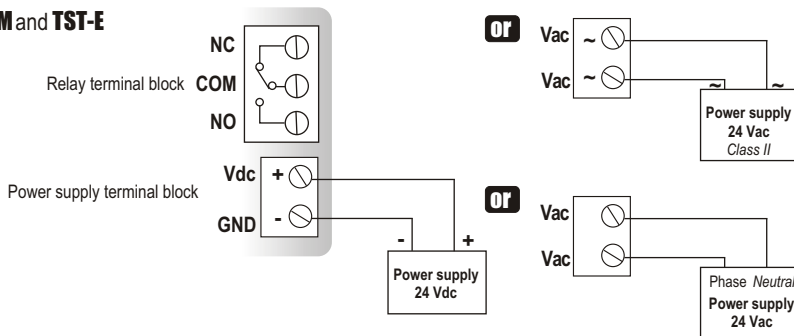

Connection of the Pt100 probe

For model

TST-B

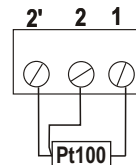

Configuration

Configuration of measuring units, set points, can be carried out different ways : **DIP switch, push-button and/or software** (connections (e), (f) and (d) on drawing "connection").

Configuration of measuring units by DIP switch

To configure the transmitter, please unscrew the 2 screws from the housing, and then open it.

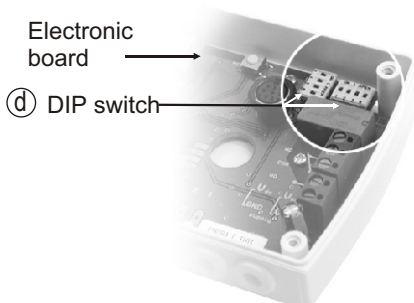

Identification of the DIP switches on the electronic board

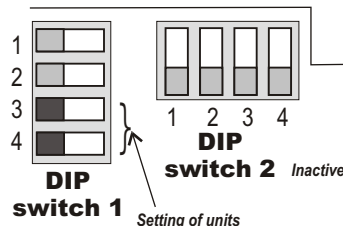

To configure the transmitter, **it must not be energized**. Then, you can make the settings required, thanks to the DIP switches (as shown on the drawing beside). When the transmitter is configured, you can power it up.

Caution !

Please follow carefully the combinations beside with the DIP switch.

If the combination is wrongly done, the following message will appear on the display of the transmitter "CONF ERROR". In that case, you will have to unplug the transmitter, replace the DIP switches correctly, and then power the transmitter up.

•Setting of units

To set the unit of measurement, please put the on-off buttons 3 and 4 of the units as shown beside.

Configurations	°C	°F
1		1
2		2
3		3
4		4

■ **Set points configuration with the push-button**

Power the transmitter up : it will then display its current configuration.
 To modify the configuration, please proceed as follows :
 Remove the 2 screws from the housing and open it.
 The settings are done with the button located on the electronic board (see photo beside).

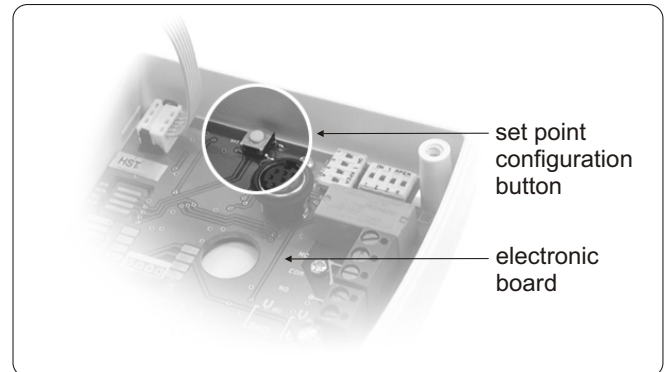

Principle :

- By pressing on this button for more than 3 seconds, you can validate a setting and go to the following setting.
- By pressing quickly on this button, you can increment a value and scroll down the different options or values.

This button enables you :

- 1- to activate/deactivate an alarm (set point)
- 2- to set the set point value
- 3- to program the action of the alarm (rising/falling action)
- 4- to set the time-delay (temporisation)

To set the different options :

1- Activating/deactivating the alarm :

After pressing the setpoint configuration button for more than 3 seconds, will be displayed, then or (depending on the last configuration of the transmitter).
 Afterwards, by briefly pressing on this button, you can switch between (alarm on) and (alarm off).
 To validate your choice, press again for 3 seconds. If you chose , then you will exit the configuration mode and switch back to the measurement mode. If you chose , you will move to the next parameter.

2- Programming the set point value :

The set point is a limit which, when being reached and/or exceeded, activates the relay and the visual red LED alarm.
 The first digit will start to blink, by briefly pressing on the button, you can choose if the set point will be either positive (0) or negative (-). Then press the button during 3 seconds to confirm your choice. The second digit will start to blink. Press the button briefly to change the value. Then press the button during 3 seconds to confirm your choice.
 Repeat this sequence until you have reached the last digit and then confirm the set point.

3- Programming the action of the alarm (rising/falling action) :

the alarm will activate when the measure exceeds the set point
 the alarm will activate when the measure goes below the set point.
 Press the button for 3 seconds to confirm your choice. You will then move on to the last parameter.

4- Setting of the time-delay (dead band temporisation 60 sec max) :

When the set point is reached and/or exceeded, the time-delay will wait the specified time before energizing the relay, if the set point is still reached and/or exceeded.
 When the first digit starts blinking, press briefly on the button to change the value. Then press the button during 3 seconds to confirm your choice. Repeat the process until all digits have the desired value and press the button for 3 seconds to confirm your choice.

The programming is now done and the display switches back to the measurement mode.

■ Initialization of the transmitter

When the transmitter is powered up, it initializes and displays the digits $\boxed{0.0.0.0.0}$, and then its configuration including :

- 1 - the measuring range
- 2 - the status of the alarm
- 3 - the set point
- 4 - action of the alarm (rising or falling action)
- 5 - time-delay (dead band temporisation)

1- The measuring range

The following message is displayed : \boxed{Lo} . This is the low value of the measuring range, and its digit value : **ex** : $\boxed{-20}$.
 The following message is displayed : \boxed{Hi} . This is the high value of the measuring range and its digit value : **ex** : $\boxed{80}$.
 The arrow displayed (at the bottom or on the right of the screen) is relative to the unit of measurement : **ex** : from -20 to 80 °C.

2 - The status of the alarm

When the alarm is off, the following message is displayed : \boxed{ALOFF} .

When the alarm is on, the following message is displayed : \boxed{ALON} .

- When the alarm is off, the transmitter displays $\boxed{----}$, which confirms the end of initialization and that you can start the measurements .
- When the alarm is on, the transmitter displays the parameters relative to the relay (set point, program of the alarm, time-delay).

3 - The set point (alarm on)

This message is displayed : **ex** : $\boxed{45}$, which means that the alarm will be activated as soon as the measurement exceeds this value.

4 - Action of the alarm (rising or falling action)

If the relay is programmed in rising action, the following message is displayed : $\boxed{-f-}$.

If the relay is programmed in falling action, the following message is displayed : $\boxed{-L-}$.

5 - The time-delay (alarm on)

This message is displayed : $\boxed{1.5E4}$.

The temporisation is in seconds (from 0 to 60 sec.).

After having displayed the configuration, the transmitter displays $\boxed{----}$, which confirms that the initialization is finished and you can start the measurements.

■ Configuration via software

(with the optional LCC100 software)

An easy and friendly way to configure!

You can configure the measuring units, the set point, the time-delay..

- To access the configuration via software, you must first position **the DIP switch**, as per the following picture (shown beside), and then connect the cable to the transmitter (see "connections" drawing).

- Please refer to the user manual of the LCC 100 to make the configuration.

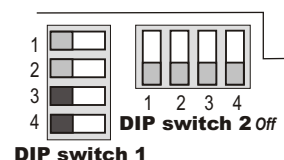

⚠ Caution !

The configuration can be made either by switch, or by software (you can not combine both solutions).

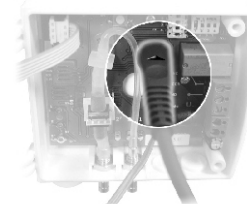

■ Mounting

Installation : mount the ABS plate on the wall (this plate is supplied with the transmitter). Drilling : $\varnothing 6$ mm, with the screws and pins supplied with the transmitter. Insert the transmitter into the plate (see points A of the drawing beside), by tilting it at 30°. Rotate the housing in clockwise direction until you hear a "click" which confirms that the transmitter is correctly installed.

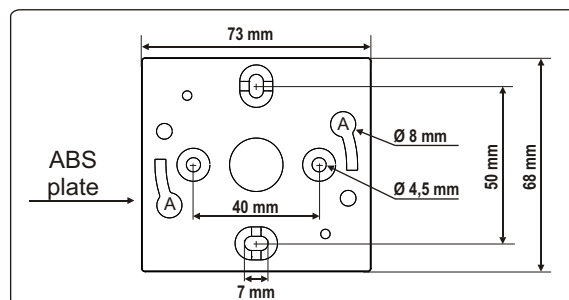

■ Maintenance

Please avoid any aggressive solvent.
 Please protect the transmitter and its probes from any cleaning product containing formol, that may be used for cleaning rooms or ducts.

Options

- Power supply class 2, input 230 Vac, output 24 Vac, ref.KIAL-100A
- Configuration software LCC 100 with RS 232 cable
- Temperature probes Pt100 3 wires



EXPORT DEPARTMENT

Tel : + 33. 1. 60. 06. 69. 25 - Fax : + 33. 1. 60. 06. 69. 29
 site : www.kimo.fr e-mail : export@kimo.fr



Distributed by :