

# Flush-mount transmitter **CPE 300**

CE

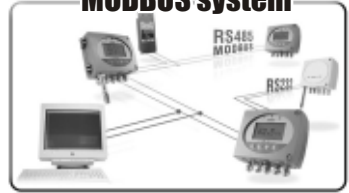





## MODBUS system



## Remote control





<b>1. Prerequisite</b> .....	P 1
1.a - Working principle .....	P 1
1.b - Output signal selection .....	P 1
<b>2. Modbus parameters</b> .....	P 3
2.a - Configuration parameters .....	P 3
2.b - Modbus functions .....	P 3
2.c - Register access security key .....	P 3
<b>3. Activation code and access to functions</b> .....	P 5
<b>4. Display configuration •  F100</b> .....	P 6
4.a - Transmitter channel for infrared remote control .....	P 6
4.b - Slave addressing (Modbus) .....	P 8
<b>5. Configuring units of measurement  F200</b> .....	P 9
<b>6. Analogue output management •  F300</b> .....	P 10
6.a - Output diagnostics .....	P 11
6.b - Analogue output settings .....	P 12
<b>7. Alarm / Relay settings •  F400</b> .....	P 14
7.a - Activation / Deactivation of BEEP alarm .....	P 14
7.b - Relay security .....	P 14
7.c - Alarm / relay functions and LED colour codes .....	P 15
7.d - Channel selection for alarms / relays .....	P 16
7.e - Alarm mode details .....	P 17
7.f - Alarm mode selection .....	P 19
7.g - Setpoint and time-delay settings .....	P 20
<b>8. Pressure measurement configuration •  F500</b> .....	P 22
8.a - Pressure measurement integration .....	P 22
8.b - Time-delay between 2 self-calibrations .....	P 22
<b>9. Other functions</b> .....	P 21
9.a - Activation / Deactivation of the RS232 and home bus .....	P 21
9.b - Serial number display .....	P 21
9.c - Modification of Modbus communication speed .....	P 22
9.d - Mode Purge .....	P 22
<b>10. Error codes</b> .....	P 24
<b>11. Functions recap</b> .....	P 25

## 1.a - Working principle

Using remote control and optional Modbus configuration, you can change units of measurement, set setpoints and relays...

**Principle:** the configuration options are accessed via **folders and sub-folders** (similar to Windows<sup>®</sup>). Access is made via a **numerical code** (full details in this manual).

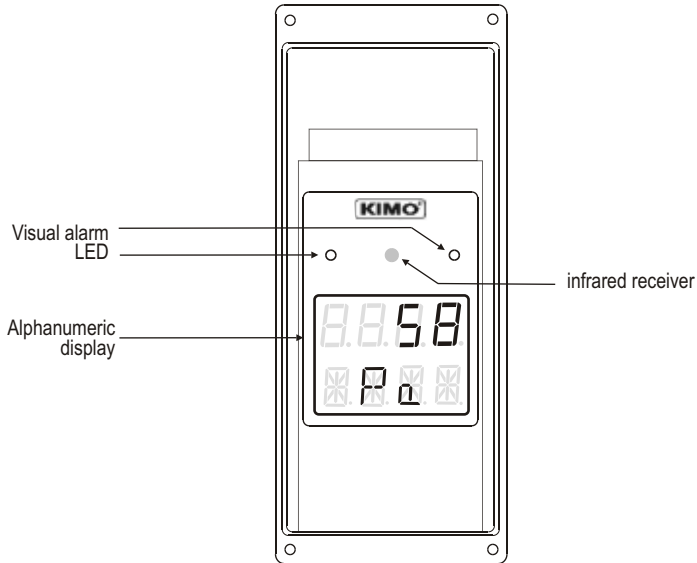

### ■ Meaning of the keys

- ⊕ To increment a value or a level
- ⊖ To decrement a value or a level
- OK To validate an input
- Esc To cancel an input or to return to the previous step

### Channel selection

With this selector, you can swap the transmission channel so that it matches with the transmitter reception channel. See page 6 to configure the transmitter reception channel.

## 1.b - Output signal selection

### Voltage or Current ?

The Class 300 can output either a **voltage** or a **current** signal.



With the on-off switch located on the left top of the transmitter (when open), you can choose analogue output 0-10V (voltage) or 4-20 mA (current)



Down  
4-20 mA



Up  
0-10 V

### 2.a - Configuration parameters

- **Communication speed** ..... 19200 Bauds (see page 22 to configure the speed)
- **Data bits** ..... 8 bits
- **Stop bit** ..... 1 bit
- **Parity** ..... None
- **Flow control** ..... None
- **Transmitter addressing** ..... between 1 and 32  
 default address "0" for single ended bus configuration  
 To change the addressing, see page 8.

### 2.b - Functions

- **Register reading** ..... Function 03
- **Register writing** ..... Function 16
- **Communication loop test** ..... Function 08

### 2.c - Access codes to Registers

- **Registers type** ..... Signed long integer (32 bits), permuted (LSB, MSB)

- **Alarms status** - Modbus code : **1436**

*Ex. The value sent by the transmitter is 5  
 Alarm condition 1  
 and relay 1 energized*

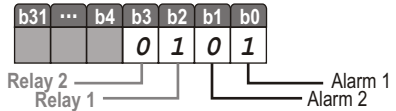

- **Values** - Modbus code : **1438 (channel 1)**  
**1442 (value 1 for the external transmitter)**  
**1446 (value 2 for the external transmitter)**  
*Ex. the value sent by the transmitter is 623*

- **Values formatting** - Modbus code : **1440 (channel 1)**  
**1444 (value 1 for the external transmitter)**  
**1448 (value 2 for the external transmitter)**

<b>Units of measurement</b>			
1	m/s	12	mmH <sub>2</sub> O
2	fpm	13	inWg
3	m3/h	14	Kpa
4	L/s	15	mmHg
5	cfm	16	mbar
6	m3/s	17	g/kg (absolute humid. <b>p</b> )
7	°C	18	°C (dew temp. <b>Td</b> )
8	°F	19	°F (dew temp. <b>Td</b> )
9	%RH	20	°C (humid temp. <b>Tw</b> )
10	PSI	21	°F (humid temp. <b>Tw</b> )
11	Pa	22	KJ/Kg (Enthalpy <b>i</b> )

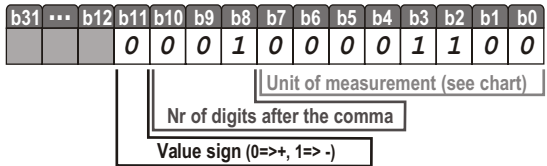

*Ex. The formatting displayed is **268**.  
 Unit of measurement => 12 (see chart)  
 Figure(s) after the comma => 1  
 Sign => positive*

*If the value measured is equal to 623 :  
**Résultat => 62.3 mmH<sub>2</sub>O***

### 2.c - Access codes to Registers (sequel)

• Serial number of SPI sensing element

Modbus code: 1402

**NOTE**

Other access codes to different registers are indicated on each function at stage n°2.

Shown as this pictogram:



#### 4.a - Canal du capteur pour la télécommande infrarouge

Écran 1 : Sélectionner le canal du capteur pour la télécommande infrarouge (0 à 15) et appuyer sur la touche F100.

Écran 2 : Sélectionner le canal du capteur pour la télécommande infrarouge (0 à 15) et appuyer sur la touche F100.

Écran 3 : Sélectionner le canal du capteur pour la télécommande infrarouge (0 à 15) et appuyer sur la touche F100.

Écran 4 : Sélectionner le canal du capteur pour la télécommande infrarouge (0 à 15) et appuyer sur la touche F100.

Écran 5 : Sélectionner le canal du capteur pour la télécommande infrarouge (0 à 15) et appuyer sur la touche F100.

### 3. Activation code and access to functions



This step is **COMPULSORY** for each configuration.

To access the transmitter functions, **and for safety**, you have to first enter a safety code.

- Please check that the transmitter is powered on.
- If the transmitter displays an error code, please see “Errors Code” section on page 22

#### Step 1

Press **OK**

to get this screen

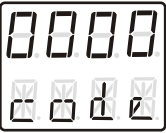

#### Step 2

Enter the CODE “0101”  
with the keypad and  
validate with **OK**

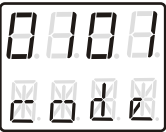

#### Step 3

This screen appears:



#### Step 4

Configuration folder  
selection

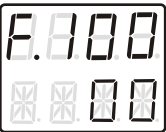

The first “0” blinks, which means that this column is activated and you can enter data from the keypad.



The code must be entered from left to right.

To **increment** a value or a level, press **+**

To **decrement** a value or a level, press **-**

To **validate a value (level) or to validate the code**, press **OK**

To return to the **previous status or to cancel**, press **Esc**



This screen confirms that the code was correctly entered, and that you can **configure the transmitter**.

If the code was wrongly entered, the transmitter initializes and returns to the

starting display.



**N° de dossier de configuration**

The transmitter includes **5 folders** maximum :

- 100
- 200
- 300
- 400
- 500

Ex. in the folder 400, you can configure the alarms and relays. See page 12.



To select your configuration folder, press **+** to increment 100 or press **-** to decrement 100.

Once the folder is selected, press **OK** to validate.



**On the top left of each page** of this manual, you can find a reminder of the configuration folder where the function is available.

**F400**

## 4.a - Transmitter channel for infrared remote control



You can change the channel number for receiving the signal from the infrared remote control.

**NOTE** By default, the channel number is **0**.



Go into the configuration mode (see page 5). The folder number displayed corresponds to the last configuration folder used.



Select the folder "100" and validate with **OK**.

Select the sub-folder "100" and validate with **OK**.  
The cursor > goes to the line of available choices.



With **+** and **-** keys, select the channel number (from 00 to 09). Validate with **OK**.



The cursor > returns to sub-folders line.

- press twice **Esc** to return to reading mode
- press once **Esc** to select another folder.
- with **+** and **-** keys, you can choose another sub-folder from the folder

## 4.b - Slave addressing (Modbus)



Go into configuration mode (see page 5). The folder number displayed corresponds to the last configuration folder used.



Select the folder "100" and validate with **OK**.

Select the sub-folder "103" and validate with **OK**.

The cursor > goes to available choices.



With **+** and **-** keys, set the slave addressing number (from 1 to 32). Validate with **OK**.



The cursor > goes to sub-folders line.

- press twice **Esc** to return to reading mode.
- press once **Esc** to return to another folder selection.
- with **+** and **-** keys to choose another sub-folder from the folder 100.

## 5. Configuring channels and units of measurement

Step  
1



Go into configuration mode (see page 5). The folder number displayed corresponds to the last configuration folder used.

Step  
2





Select the folder "200" and validate with . The cursor > goes to choices line.



Step  
3



With  and  keys, select the unit of measurement (see chart below). Validate with .





00	Pa
01	mmH <sub>2</sub> O
02	inWg
03	mbar



Step  
4



The cursor > returns to sub-folders line.

- press twice  to return to reading mode.
- press once  to return to another folder selection.
- with  and  keys to choose another sub-folder from the folder 200.

## 6.a - Output diagnostics

With this function, you can check with a multimeter (or a regulator/display, or a PLC/BMS) if the transmitter outputs are working properly. The transmitter generates a current (between 4 and 20mA) or a voltage (between 0 and 10V).

### 6.a.1 - Multimeter connection configuration

Before carrying out the output diagnostics, all connections and configurations of the transmitter must be enabled, to avoid any damage on the transmitter and the multimeter!



**Example of connection**

On the photo alongside, the multimeter is connected to the 0-10 V output.

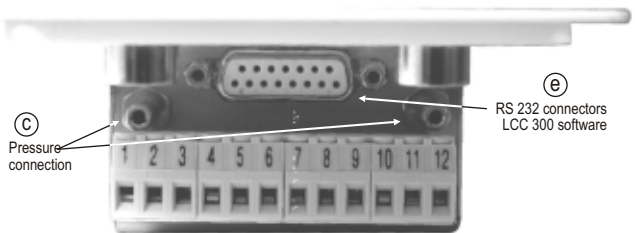

**c** Pressure connection

**e** RS 232 connectors LCC 300 software

**d** Analogue output

**a** Power supply

**b** Relays terminal blocks

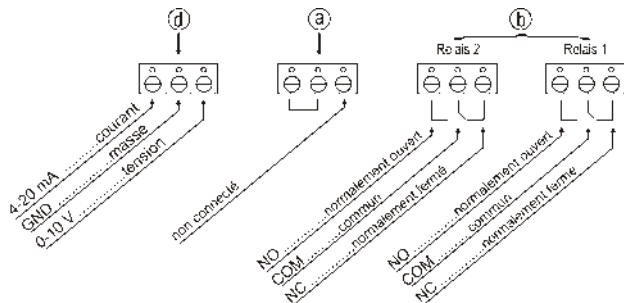

### 6.a.2 - Output diagnostics

Once the connection of the transmitter to the multimeter (or regulator or PLC/BMS is complete, (see page 8), you can carry out the analogue output diagnostics on several check points.

Step  
1



Go into configuration mode (see page 5). The folder number displayed corresponds to the last configuration folder used.

Step  
2





Select the folder "300" and validate twice with . The cursor > goes to available choices.



Step  
3



With  and  keys, select the signal that the transmitter must output (see chart below). Note : no need to validate with .

	<i>D diagnostic Output</i>
00	0 V
01	5 V
02	10 V
03	4 mA
04	12 mA
05	20 mA







**If the deviations are too large (>0,05V or >0,05mA) between the signal issued and the value displayed on the multimeter, we recommend that you return the transmitter to our factory.**

Step  
4



The cursor > returns to sub-folders line.

- press twice  to return to reading mode.
- press once  to return to another folder selection.
- with  and  keys to choose another sub-folder from the folder 300.

## 6.b - Analogue output settings

With this function, you can modify the measuring range of the transmitter, and you can equate the new limits to the analogue output (0-10V or 4-20mA).

You can enter the measuring range required on your own !



**You must enter the values according to the units of measurement selected, not according to the measuring range of the transmitter.**

*Ex. on a CPE 303 pressure transmitter (0 to  $\pm 1000$  Pa) with a reading in mmH<sub>2</sub>O, the minimum and maximum ranges must be configured on measuring range of 0 to  $\pm 102$  mmH<sub>2</sub>O. See conversion chart on following page.*

Step  
1

Entrer en mode configuration (cf. page 5). Le numéro de dossier affiché correspond au dernier dossier de configuration utilisé.

Step  
2

Select the folder "300" and validate with **OK**.

### Minimum of output

Select sub-folder "301" and validate with **OK**.  
The cursor > returns to the input line.



Step  
3

With **+** and **-** keys, select the minimum limit value and validate with **OK**.  
Note : in the left column, you can have either a integer (from 0 to 9) or a negative sign for a negative minimum limit.

Step  
4

### Maximum of output

Select sub-folder "302" and validate with **OK**.  
The cursor > returns to the input line.



Step  
5

With **+** and **-** keys, select the maximum limit value and validate with **OK**.  
Note : in the left column, you can have either a integer (from 0 to 9) or a negative sign for a negative maximum limit.

**!** Nous préconisons un delta entre le minimum et le maximum > 5% de l'étendue de mesure

Step  
6

The cursor > goes to sub-folders line.

- press twice **Esc** to return to reading mode.
- press once **Esc** to return to another folder selection.
- with **+** and **-** keys you can choose another sub-folder from the folder 300.

**NOTE**

After an analogue output setting, if the unit of measurement is modified (see page 5), you have to reconfigure the outputs according to the new unit of measurement.

### 6.b.1 - Units of measurement conversion chart

#### Pressure

	<i>Pa</i>	<i>mmH2O</i>	<i>inWg</i>	<i>mbar</i>
<b>CPE 301</b>	0 to $\pm 100$	0 to $\pm 10,2$	0 to $\pm 0,40$	0 to $\pm 1,00$
<b>CPE 302</b>	0 to $\pm 500$	0 to $\pm 51,0$	0 to $\pm 2,01$	0 to $\pm 5,00$
<b>CPE 303</b>	0 to $\pm 1000$	0 to $\pm 102,0$	0 to $\pm 4,02$	0 to $\pm 10,00$

## 7.a - Activation / Deactivation of BEEP alarm

The beep alarm (audible alarm) is activated when a set point is reached.  
For more details on the setpoint settings, see page 20.

Step  
1



Go into configuration mode (page 5). The folder number displayed corresponds to the last configuration folder used.

Step  
2



Select the folder "400" and validate with  $\odot$ .  
Select sub-folder "400" and validate with  $\odot$ .  
The cursor > goes to available choices.



Step  
3



With  $\oplus$  and  $\ominus$  keys, select **01** to **activate** the BEEP alarm or **00** to **deactivate**. Validate with  $\odot$ .

Step  
4



The cursor > goes to sub-folders line.

- press twice on  $\text{Esc}$  to return to reading mode.
- press once on  $\text{Esc}$  to return to another folder selection.
- with  $\oplus$  and  $\ominus$  keys you can choose another sub-folder from the folder 400.

## 7.b - Relay security

The relay outputs are by default, in **negative security**: the relay is **energized** when a set point is reached. With the remote control, you can swap the relays in **positive security**: then, the relay is **de-energized** when a set point is reached or during a power outage.

Step  
1



Enter in configuration mode (see page 5). The folder number displayed corresponds to the last configuration folder used.

Step  
2

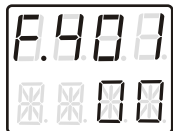

Select folder "400" and validate with  $\odot$ .  
Select sub-folder "401" and validate with  $\odot$ .  
The cursor > goes to available choices.



Step  
3



With the keys  $\oplus$  and  $\ominus$ , select **01** for a **positive** security or **00** for a **negative** security. Validate with  $\odot$ .

Step  
4



The cursor > returns to sub-folders line.

- press twice on  $\text{Esc}$  to return to reading mode.
- press once on  $\text{Esc}$  to return to another folder selection.
- with  $\oplus$  and  $\ominus$  keys, you can choose another sub-folder from the folder 400.



## 7.c - Alarm / relay functions and LED colour codes

### 7.c.1 - Visual / audible alarms

Class 300 transmitters have 2 visual / audible alarms located in front of the transmitter, allowing to know the condition of the setpoints.

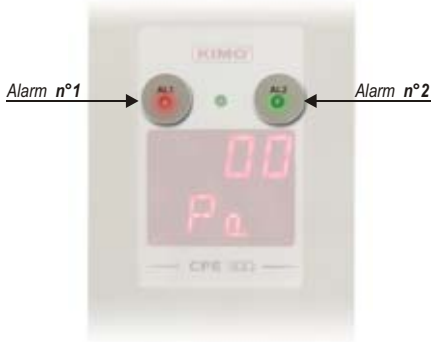

#### Alarm LED colour codes

- Green** The alarm function is activated and the set point is not reached
- Red** The alarm function is activated and the setpoint is reached
- None** The alarm function **is not activated**



The red LED appears when the setpoint is reached, taking into account the time-delay and the action type (falling or rising). See page 17 for more details.

#### Audible alarm

**Once the alarm is activated**, an alarm sounds whilst the setpoint is reached.



The BEEP alarm function must be activated to use the audible alarm. See page 12.

## 7.d - Alarm mode details

### 7.d.1 - Definitions

#### Setpoint

The setpoint is a limit which, on being reached and/or exceeded, activates an alarm or energizes a relay (in negative security, see page 14 for more details).

#### Time-delay

Once the setpoint is reached and/or exceeded, the time-delay postpones the alarm activation (or relay excitation) for a short period (in seconds). Once this period is elapsed, and if the setpoint is still exceeded, then the alarm is activated or the relay is energized (in negative security).

#### Action type

For alarm activation or relay excitation, you can choose the action type: rising or falling action.

- **Rising action:** the alarm is activated once the measurement **goes over** the setpoint
- **Falling action:** the alarm is activated once the measurement **goes below** the setpoint

### 7.d.2 - Available configurations

Configuration N°1 : 2 setpoints and time-delay activated (Control Mode)

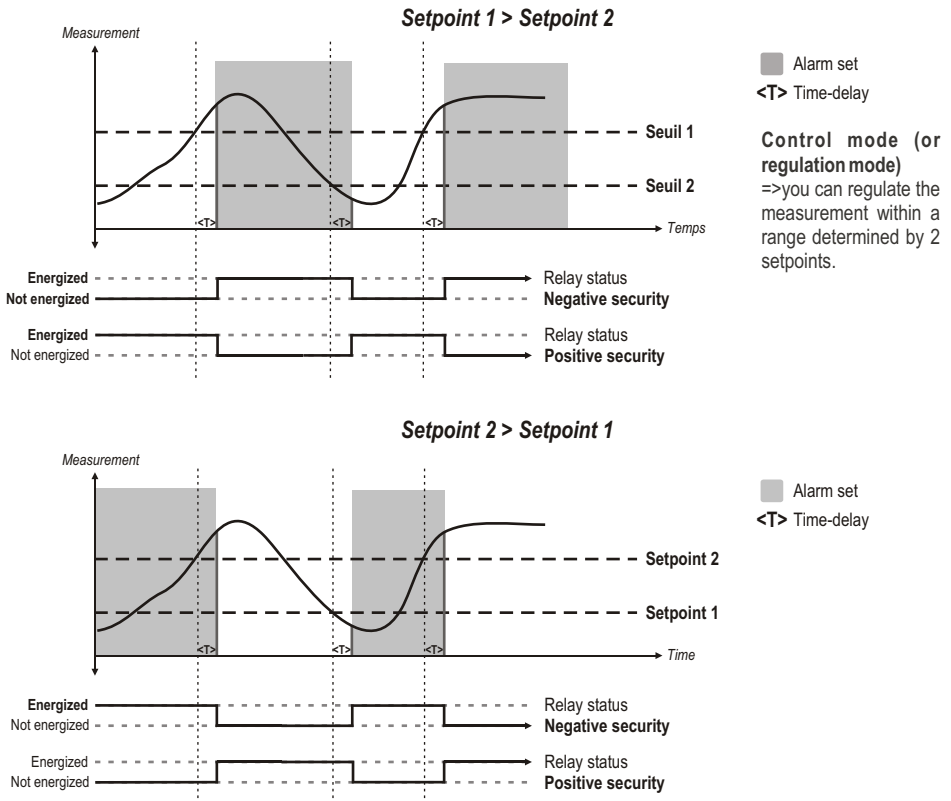

**Configuration N°2 : 1 setpoint, time-delay and rising action activated**

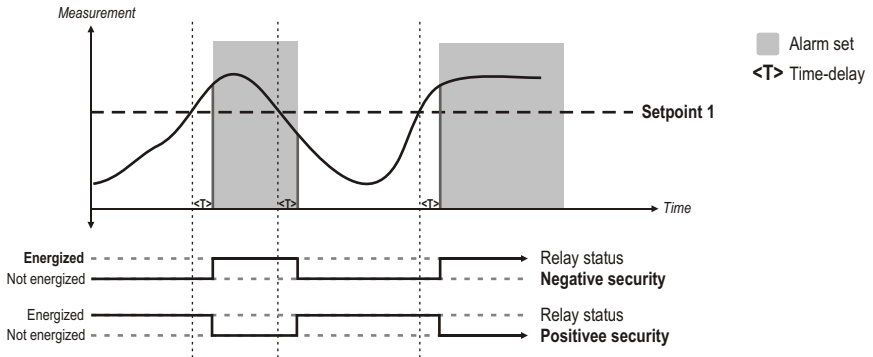

**Configuration N°3 : 1 setpoint, time-delay and falling action activated**

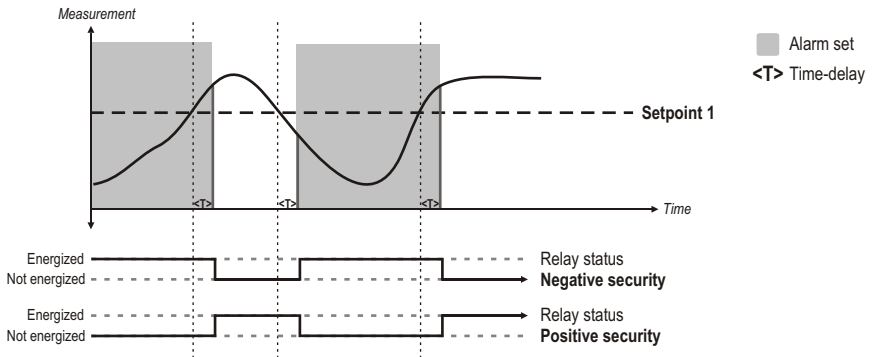

### 7.e - Alarm mode selection



Go into configuration mode (see page 5). The folder number displayed corresponds to the last configuration folder used.



Select the folder "400" and validate with  $\odot$ .

Select sub-folder



and validate with  $\odot$ .



With  $\oplus$  and  $\ominus$  keys, select the code relative to the alarm mode (see chart below). Validate with  $\odot$ .

Code	Mode d'alarme	Schema
00	No alarm	
01	2 setpoints with time-delay (control mode)	N° 1 page 14
02	1 setpoint with time-delay and rising action	N° 2 page 15
03	1 setpoint with time-delay and falling action	N° 3 page 15



The cursor > returns to sub-folders line.

- press twice  $\text{Esc}$  to return to reading mode.
- press once  $\text{Esc}$  to return to another folder selection.
- with  $\oplus$  and  $\ominus$  keys, you can choose another sub-folder from the folder 400.

## 7.f - Setpoints and time-delay setting

### 7.f.1 - Setpoints

Step  
1

E.400

Go into configuration mode (see page 5). The folder number displayed corresponds to the last configuration folder used.

Step  
2

E.403

Select the folder "400" and validate with .

To configure the **setpoint 1**, select sub-folder

"403"  
Alarm 1

"407"  
Alarm 2

"411"  
Relay 1

"415"  
Relay 2

and validate with .

To configure the **setpoint 2** (alarm in **control mode**, see p17),  
select sub-folder

"404"  
Alarm 1

"408"  
Alarm 2



"412"  
Relay 1

"416"  
Relay 2

and validate with .

Step  
3

0000

With  and  keys, select the setpoint value and validate with .

Note : the left column can be either a integer (from 0 to 9) or a negative sign for a negative setpoint.







**You must enter values according to the units of measurement selected, not according to the measuring range of the transmitter.**

*Ex. on a CP 303 pressure transmitter (0 to  $\pm 1000$  Pa) with a reading in mmH<sub>2</sub>O, the minimum and maximum ranges must be configured on measuring range of 0 to  $\pm 102$  mmH<sub>2</sub>O. See [conversion chart on page 11](#).*

Step  
4

0000

The cursor > returns to sub-folders line.

- press twice  to return to reading mode.
- press once  to return to another folder selection.
- with  and  keys, you can choose another sub-folder from the folder 400.

NOTE

If after having set up a setpoint, the unit of measurement is modified (see page 9), then you have to reconfigure the setpoints according to this new unit of measurement.

### 7.f.2 - Time-delay

Step  
1



Go into configuration mode (see page 5). The folder number displayed corresponds to the last configuration folder used.

Step  
2



Select the folder "400" and validate with **OK**.

Select sub-folder

"405"  
Alarm 1

Modbus  
810

"409"  
Alarm 2

Modbus  
818

"413"  
Relay 1

Modbus  
826

"417"  
Relay 2

Modbus  
834

and validate with **OK**.

Step  
3



Valider avec **OK**. With **+** and **-** keys, set the required time-delay: from 00 to 50 seconds. If you do not need the time-delay, enter 00..  
Validate with **OK**.

Step  
4



The cursor > returns to sub-folders line.

- press twice **Esc** to return to reading mode.
- press once **Esc** to return to another folder selection.
- with **+** and **-** keys, you can choose another sub-folder from the folder 400.

### 8.a - Pressure measurement integration

The integration coefficient makes an average of the measurements: this helps to avoid any excessive variations and guarantees a stable measurement.

**New value displayed** =  $(((10 - \text{Coef.}) \times N^{\text{th}} \text{ Value}) + (\text{Coef.} \times \text{former value})) / 10$

This value is applicable when the variation is **less than +/- (Coef. x 10 Pa)**

**Example : CPE303 (0-1000 Pa) - First measurement: 120 Pa - New measurement : 125 Pa**  
 The pressure source is stable, the user applied a low integration. Integration : 1, maximum variation allowed +/-10Pa. Since the variation is less than 10 Pa, we apply the integration calculation formula. Next measurement displayed  $((9 \times 125) + (1 \times 120)) / 10 = 124.5$  soit 124 Pa. If the new value had been 131 Pa, the next value displayed would have been 100% of the new value, i.e 131 Pa.

Step  
1



Go into configuration mode (see page 5). The folder number displayed corresponds to the last configuration folder used.

Step  
2



Select the folder "500" and validate with .

Sélectionner le sous-dossier "500" et valider avec .

Le curseur descend sur la ligne des choix possibles.



Step  
3



you can set the integration value: from 00 to 09.

Validate with .

**Coefficient 0** : no integration, large variation of the measurement displayed.

**Coefficient 9** : maximum integration, more stable measurement display.

Step  
4



The cursor > returns to sub-folders line.

- press twice  to return to reading mode.

- press once  to return to another folder selection.

- with  and , you can choose another sub-folder from the folder 500.

### 8.b - Time-delay between 2 self-calibrations

Step  
1



Go into configuration mode (see page 5). The folder number displayed corresponds to the last configuration folder used.

Step  
2



Select the folder "500" and validate with **OK**.

Select the sub-folder "501" and validate with **OK**.

The cursor > goes to available choices.



Step  
3



With **+** and **-** keys, you can set the time-delay values between 2 self-calibrations: from 0 to 60 minutes. Validate with **OK**.

**Note** : if the value is equal to 0, the transmitter will not carry out any self-calibration

Step  
4



The cursor > returns to sub-folder line.

- press twice **Esc** to return to reading mode.

- press once **Esc** to return to another folder selection.

- with **+** and **-** keys, you can choose another sub-folder from the folder 500

**NOTE**

Whenever you want, in reading mode, you can carry out a self-calibration by keeping "ESC" pressed

### 9.a- Activation / deactivation of the RS232 and home bus

CPE 300 transmitters have one RS232 and one RS 485 digital output (Modbus protocol) - optional. With the RS 232, you can display 1 or 2 parameters which are measured by other Class 200 and 300 transmitters, or you can send measurements to be displayed on another Class 300 transmitters.



If you set up your transmitter to send measurements to another transmitter via RS 232, then you will not be able to use the RS 485 digital output anymore (Modbus - optional).

Step  
1



Go into configuration mode (see page 5). The folder number displayed corresponds to the last configuration folder used.

Step  
2



Select the folder "100" and validate with . Select the sub-folder "101" and validate with .



Step  
3



With and keys, select to receive data from another transmitter (Home BusRS485 Modbus **active**) or select to send data via RS 232 (Home Bus RS485 Modbus **inactive**) . Validate with .

Step  
4



The cursor > returns to sub-folders line.  
 • press twice to return to reading mode.  
 • press once to return to another folder selection.  
 • with and keys, you can choose another sub-folder from the folder 100.



### 9.b- Serial number display

Step  
1



Go into configuration mode (see page 5). The folder number displayed corresponds to the last configuration folder used.

Step  
2

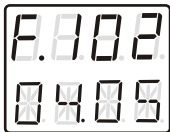

Select the folder "100" and validate with . Select the sub-folder "102"



Step  
3



Le numéro de série de l'appareil est affiché à l'écran (en 2 parties alternées). Le curseur retourne sur la ligne des sous-dossiers.

- appuyer 2 fois sur pour revenir en mode lecture des valeurs.
- appuyer 1 fois sur pour revenir à la sélection d'un autre dossier.
- utiliser et pour choisir un autre sous-dossier du dossier 100

## 9.c- Modification of Modbus communication speed

Step  
1



Go into configuration mode (see page 5). The folder number displayed corresponds to the last configuration folder used.

Step  
2



Select the folder "100" and validate with **OK**.

Select the sub-folder "104" and validate with **OK**.

Step  
3



With **+** and **-** keys, select a communication speed (see chart below). Validate with **OK**.



00	2400 bauds	03	19200 bauds (speed by default)
01	4800 bauds	04	38400 bauds
02	9600 bauds	05	115200 bauds

Step  
4



The cursor **>** returns to sub-folders line.

- press twice **Esc** to return to reading mode.
- press once **Esc** to return to another folder selection.
- with **+** and **-** keys, you can choose another sub-folder from the folder 100.

## 9.d- Purge mode

The purge mode enables to freeze the measurement when being displayed, enables to lock the analogue outputs, and to activate the relay 1, in order to actuate a de-dust system of a air movement conditions.

### 9.d.1-Activation / deactivation of Purge Mode

Step  
1



Go into configuration mode (see page 5). The folder number displayed corresponds to the last configuration folder used.

Step  
2



Select the folder "300" and validate with **OK**.

Select the sub-folder "306" and validate with **OK**.

Step  
3



With **+** and **-** keys, activate (01) or deactivate (00) the purge mode. Validate with **OK**.



Step  
4



The cursor **>** returns to sub-folders line.

- press twice **Esc** to return to reading mode.
- press once **Esc** to return to another folder selection.
- with **+** and **-** keys, choose another sub-folder from the folder 300



### 9.d.2 -Working duration of purge mode

Step  
1



Go into configuration mode (see page 5). The folder number displayed corresponds to the last configuration folder displayed.

Step  
2



Select the folder "300" and validate with **OK**.

Select the sub-folder "307" and validate with **OK**.

Step  
3



With **+** and **-** keys, enter the value in seconds of the required working duration of each purge (from 01 to 50). Validate with **OK**.



Step  
4



The cursor > returns to sub-folders line.

- press twice **ESC** to return to reading mode.
- press once **ESC** to return to another folder selection.
- press **+** and **-** to choose another sub-folder from the folder 300

### 9.d.3 -Frequency

Step  
1



Go into configuration mode (see page 5). The folder number displayed corresponds to the last configuration folder used.

Step  
2



Select the folder "300" and validate with **OK**.

Select the sub-folder "308" and validate with **OK**.

Step  
3



With keys **+** and **-**, enter the value in minutes of the frequency of each purge (from 01 to 9999). Validate with **OK**.



Step  
4



The cursor > returns to sub-folders line.

- press twice **ESC** to return to reading mode.
- press once **ESC** to return to another folder selection.
- with **+** and **-**, choose another sub-folder from the folder 300.



### 12.d.4 - Time-delay

Once the purge is finished, time-delay is a time period before the transmitter returns to measurement mode and before the analogue outputs are reactivated.

Step  
1



Go into configuration mode (see page 5). The folder number displayed corresponds to the last configuration folder used.

Step  
2

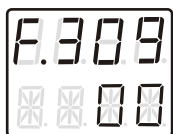

Select the folder "300" and validate with **OK**.  
Select the sub-folder "309" and validate with **OK**.

Step  
3



With **+** and **-** keys, enter the value in seconds of the time-delay required (from 00 to 50). Validate with **OK**.



Step  
4



The cursor > returns to the sub-folders line.  
• press twice **ESC** to return to reading mode.  
• press once **ESC** to return to another folder selection.  
• with **+** and **-** keys, choose another sub-folder from the folder 300.

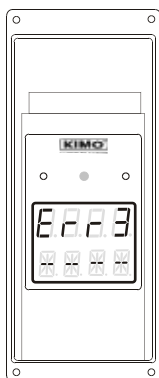

### Problem :

- Interchangeable Measuring Sensor (SPI element) not connected

### Solution :

- Connect the probe / SPI (see SPI notice)

## F.100

Code		Description	Available settings												
100	200	Channel n° for IR remote control	0 to 9												
101	202	Sending data via Rs232	0 or 1												
102	204	Serial number display													
103	206	Modbus slave number	1 to 32												
104	208	Modbus communication speed	<table border="1"> <tr> <td>00</td> <td>2400 bds</td> <td>02</td> <td>9600 bds</td> <td>04</td> <td>38400 bds</td> </tr> <tr> <td>01</td> <td>4800 bds</td> <td>03</td> <td>19200 bds</td> <td>05</td> <td>115200 bds</td> </tr> </table>	00	2400 bds	02	9600 bds	04	38400 bds	01	4800 bds	03	19200 bds	05	115200 bds
00	2400 bds	02	9600 bds	04	38400 bds										
01	4800 bds	03	19200 bds	05	115200 bds										

## F.200

Code		Description	Available settings								
200	400	Unit of channel 1	<table border="1"> <tr> <td>00</td> <td>Pa</td> </tr> <tr> <td>01</td> <td>mmH<sub>2</sub>O</td> </tr> <tr> <td>02</td> <td>inWg</td> </tr> <tr> <td>03</td> <td>mbar</td> </tr> </table>	00	Pa	01	mmH <sub>2</sub> O	02	inWg	03	mbar
00	Pa										
01	mmH <sub>2</sub> O										
02	inWg										
03	mbar										

## F.300

Code		Description	Available settings
300	600	Analogue output setting on channel 1	0=>0V, 1=>5V, 2=>10V 3=>4mA, 4=>12mA, 5=>20mA
301	602	Analogue output minimum on channel 1	
302	604	Analogue output maximum on channel 1	
306	612	Activation / Deactivation of purge mode	00 or 01
307	614	Working time of each purge	from 01 to 60 seconds
308	616	Frequency of each purge	from 01 to 9999 minutes
309	618	Time-delay after purge	from 00 to 60 seconds

## F.500

Code		Description	Available settings
500	1000	Measurement integration	from 0 to 9
501	1002	Self-calibration for time-delay	from 0 to 60 minutes



Code	 Description	Available settings
400	<b>800</b> Audible alarm	0 or 1
401	<b>802</b> Relays security	0 (negative) or 1 (positive)
<b>ALARM 1</b>	402 <b>804</b> Channel selection for alarm 1	0=>inactive 1=> setpoint 1, setpoint 2 and time-delay 2=> setpoint 1, time-delay and rising action 3=> setpoint 1, time-delay, and falling action
	403 <b>806</b> Setpoint 1 of alarm 1	
	404 <b>808</b> Setpoint 2 of alarm 1	
	405 <b>810</b> Time-delay on alarm 1	from 0 to 60 seconds
<b>ALARM 2</b>	406 <b>812</b> Channel selection for alarm 2	0=>inactive 1=> setpoint 1, setpoint 2 and time-delay 2=> setpoint 1, time-delay and rising action 3=> setpoint 1, time-delay and falling action
	407 <b>814</b> Setpoint 1 of alarm 2	
	408 <b>816</b> Setpoint 2 of alarm 2	
	409 <b>818</b> Time-delay on alarm 2	from 0 to 60 seconds
<b>RELAY 1</b>	410 <b>820</b> Alarm type selection for Relay 1	0=> inactive 1=> setpoint 1, setpoint 2 and time-delay 2=> setpoint 1, time-delay and rising action 3=> setpoint 1, time-delay and falling action
	411 <b>822</b> Setpoint 1 of Relay 1	
	412 <b>824</b> Setpoint 2 of Relay 1	
	413 <b>826</b> Time-delay on Relay 1	from 0 to 60 seconds
<b>RELAY 2</b>	414 <b>828</b> Alarm type selection for Relay 2	0=> inactive 1=> setpoint 1, setpoint 2 and time-delay 2=> setpoint 1, time-delay and rising action 3=> setpoint 1, time-delay and falling action
	415 <b>830</b> Setpoint 1 of Relay 2	
	416 <b>832</b> Setpoint 2 of Relay 2	
	417 <b>834</b> Time-delay on Relay 2	from 0 to 60 seconds





Ref. NT ang - CPE300 - 05/05 B We reserve the right to modify the characteristics of our products without notice.

**www.kimo.fr**

**EXPORT DEPART MENT**

Boulevard de Beaubourg

Emerainville - BP 48

77312 MARNELA VALLEE CEDEX 2

Tel : + 33.1.60.06.69.25

Fax : + 33.1.60.06.69.29

